



EDIZ.
4

EDIZ.
3

EDIZ.
2

EDIZ.
1

mod. UTDIN. DWG

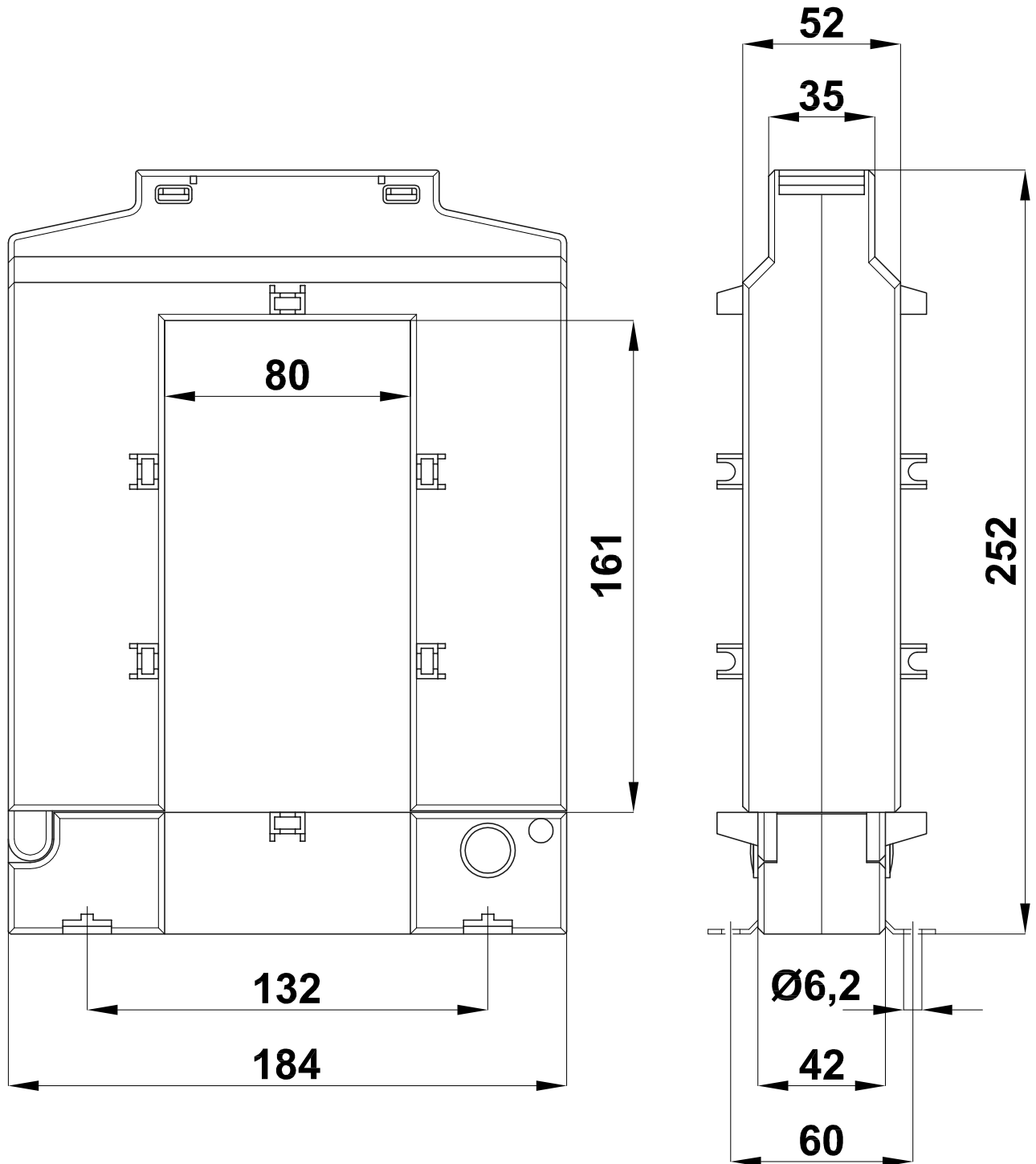

DIS.

DIMENSIONI D'INGOMBRO PER:
OVERALL DIMENSIONS FOR:

SCALA

1:2

EDIZ.

DATA

TRASFORMATORE AMPEROMETRICO APRIBILE TAA162
TAA162 SPLIT CORE CURRENT TRANSFORMER

DOC.N.

UTDINI408.0

0 04/07/17