

ZMD300AT/CT  
E650 Series 3  
User Manual



Date: 29.10.2013

File name: D000030108 E650 ZMD300xT Series 3 User Manual en m.docx

# Revision history

Version	Date	Comments
a	01.07.2009	First edition
b	15.10.2009	Corrections to type designation table in section 1.3 Incorrect note on ZMD/ZFD meters removed from section 1.4 Fig. 4.11 replaced Referenced documents corrected in section 1.8 Error code F.F 00 00 2x 00 added in section 6.2.2 Error Groups Various grammatical and language errors corrected throughout the document
c	12.11.2009	Minor formatting and typing errors corrected
d	03.12.2009	Minor formatting and typing errors corrected
e	01.06.2010	Update for firmware version B31
f	08.11.2010	Information concerning losses removed
g	27.01.2011	Updated document template and section 1.3 table entry "045x 4 outputs, additional power supply 100-240 VAC/VDC" Optional red LED added to outputs in section 1.4 ZFD400 column removed from the table in section 1.5.3 Footnote added after table in section 1.5.3 Reactive energy section modified in section 1.5.4 Summation channels section modified in section 1.5.4 Section 3.1 retitled "Housing"
h	05.10.2011	Updated document template. Comment regarding grounding inserted in section 4.1.2. Section 5.3.3 "Index System" simplified and new section 11 "Appendix OBIS Code" inserted.
k	26.09.2012	Update for firmware version B32. New extension board 326x. New measured quantities. New events. New integrated terminal cover switch. Updated document template. Section "Safety" becomes first section. OBIS explanation expanded. New representation of value change procedure in set mode. Minor text improvements and corrections of formatting and typing errors.
m	29.10.2013	Synchronised document version indicators across all languages. Updated disclaimer. Reformatted warnings, cautions and notes. Corrected minor terminology, spelling and punctuation errors. Added extension board 047x to section 2.3 "Type designation". Added information on 3-phase, 3-wire (no neutral) connections to section 3.4 "Connection diagrams (examples)". Added extension board 0470 to section 3.4 "Connection diagrams (examples)".

Although the information contained within this document are presented in good faith and believed to be correct, Landis+Gyr (including its affiliates, agents and employees) disclaim any and all liability for any errors, inaccuracies or incompleteness relating to the product. Landis+Gyr makes no warranty, representation or guarantee regarding the performance, quality, durability or suitability of the products for any particular purpose. To the fullest extent permitted by law Landis+Gyr disclaims (1) any and all liability arising out of the use of the product, (2) any and all liability, including, but without limitation to, special, consequential and indirect damages and losses, and (3) any and all implied warranties, including, but without limitation to, fitness for purpose and merchantability.

The information contained in this document is strictly confidential and is intended for the addressee only. The unauthorised use, disclosure, copying, alteration or distribution of this document or the contents thereof is strictly prohibited and may be unlawful.

All product information are subject to change without notice.

# Table of contents

Revision history.....	2
Table of contents .....	3
About this document .....	5
<b>1 Safety.....</b>	<b>6</b>
1.1 Safety information .....	6
1.2 Responsibilities .....	6
1.3 Safety regulations .....	7
1.4 Radio Interference .....	7
<b>2 Device description.....</b>	<b>8</b>
2.1 Field of application .....	8
2.2 Characteristics .....	8
2.3 Type designation.....	10
2.4 Block schematic diagram .....	11
2.5 Measuring system.....	14
2.5.1 Input signals .....	14
2.5.2 Signal processor.....	15
2.5.3 Measured quantities .....	17
2.5.4 Formation of measured quantities .....	18
2.5.5 Summation channels.....	22
2.6 Data profile.....	22
2.6.1 Stored value profile .....	23
2.6.2 Load profile 1 and load profile 2 (option).....	23
2.6.3 Event log .....	23
2.7 Communication .....	26
2.7.1 Optical interface .....	26
2.7.2 Communication units .....	26
2.8 MAP software tools .....	27
2.9 Anti-tampering features.....	28
2.9.1 DC magnet detection.....	29
2.9.2 Terminal cover detection .....	29
<b>3 Mechanical construction .....</b>	<b>30</b>
3.1 Housing.....	30
3.2 Faceplates .....	33
3.3 Connections .....	34
3.4 Connection diagrams (examples) .....	35
3.5 Dimensions .....	39
<b>4 Installation and uninstallation.....</b>	<b>40</b>
4.1 Basic information for connecting meter.....	40
4.1.1 Connection with 3 phases and neutral .....	40
4.1.2 Connection with 3 phases without neutral (Aron circuit).....	40
4.2 Mounting the meter .....	40
4.3 Connecting meter.....	42
4.3.1 Connecting the RS485 interface.....	45
4.4 Check of connections.....	46
4.5 Commissioning, functional check and sealing .....	46
4.6 Installation of terminal cover detection.....	47
4.7 Uninstallation .....	48
<b>5 Operation.....</b>	<b>50</b>

5.1	Operation with auxiliary power supply .....	50
5.2	Control elements .....	50
5.2.1	Display buttons .....	50
5.2.2	Control of display via optical interface.....	51
5.2.3	Reset button.....	51
5.3	Display.....	52
5.3.1	Introduction .....	52
5.3.2	Basic layout.....	52
5.3.3	Index system.....	53
5.4	Types of display.....	54
5.4.1	Operating display .....	54
5.4.2	Display menu .....	55
5.4.3	Service menu .....	58
5.5	Alert LED .....	59
5.6	Optical test output.....	59
5.7	Data readout.....	60
5.7.1	Readout to IEC 62056-21 .....	60
5.7.2	Readout to DLMS.....	62
5.8	Input of formatted commands.....	63
5.9	Set time and date, ID numbers, battery time .....	64
<b>6</b>	<b>Service .....</b>	<b>65</b>
6.1	Operating faults .....	65
6.2	Error messages .....	65
6.2.1	Structure of an error message .....	66
6.2.2	Error groups .....	66
6.3	Repairing meters .....	71
<b>7</b>	<b>Maintenance .....</b>	<b>72</b>
7.1	Meter testing.....	72
7.1.1	Test mode .....	72
7.1.2	Measuring times.....	72
7.1.3	Optical test output .....	73
7.1.4	No-load test.....	74
7.1.5	Starting test active part .....	74
7.1.6	Starting test reactive part .....	75
7.2	Changing the battery .....	75
<b>8</b>	<b>Disposal .....</b>	<b>77</b>
<b>9</b>	<b>Index.....</b>	<b>78</b>
<b>Appendix 1</b>	<b>OBIS code .....</b>	<b>81</b>

# About this document

**Range of validity** The present user manual applies to the meters specified on the title page.

**Purpose** The user manual contains all the information required for metering applications for the intended purpose. This includes:

- Provision of knowledge concerning the characteristics, construction and function of the meters
- Information about potential dangers, their consequences and measures to prevent any danger
- Details about the performance of all activities throughout the service life of the meters (parameterisation, installation, commissioning, operation, maintenance, decommissioning and disposal)

**Target group** The content of this user manual is intended for technically qualified personnel of utilities (energy supply companies), responsible for system planning, installation and commissioning, operation, maintenance, decommissioning and disposal of meters.

**Reference documents** The following documents provide further information related to the subject of this document:

- D000030104 "E650 ZMD300AT/CT Series 3 Technical Data"
- D000030112 "E650 ZxD Series 3 Functional Description"

**Conventions** The structure and significance of meter type designations are described in section 2.3 "Type designation". The following conventions are employed in this user manual for representing type designations:

- The lower case letter "x" can be used as an unknown to indicate different versions (e.g. ZMD310xT for the ZMD310AT and ZMD310CT meters).
- The following collective terms are also sometimes used instead of the type designation:
  - "Active energy meters" for the ZMD300AT meters
  - "Combi-meters" for the ZMD300CT meters

# 1 Safety

This section describes the safety information used in this manual, outlines the responsibilities and lists the safety regulations to be observed.

## 1.1 Safety information

The following symbols are used to draw your attention to the relevant danger level, i.e. the severity and probability of any danger, in the individual sections of this document.

**Warning**

Used to indicate a dangerous situation that could cause bodily injury or death.

---

**Caution**

Used to indicate a situation/ action that could result in material damage or loss of data.

---

**Note**

Used to indicate general guidelines and other useful information.

---

In addition to the danger level, safety information also describes the type and source of the danger, its possible consequences and measures for avoiding the danger.

## 1.2 Responsibilities

The owner of the meters – usually the utility company – is responsible for ensuring that all persons working with meters:

- Have read and understood the relevant sections of the user manual.
- Are appropriately qualified for the work to be performed.
- Strictly observe the safety regulations (laid down in section 1.3) and the operating instructions as specified in the individual sections.

In particular, the owner of the meters bears responsibility for the protection of persons, prevention of material damage and the training of personnel.

For this purpose, Landis+Gyr provides training on a variety of products and solutions. Please contact your local Landis+Gyr representative if interested.

## 1.3 Safety regulations

The following safety regulations must be observed at all times:

- The meter connections must be disconnected from all voltage sources during installation or when opening.
- Contact with live parts can be fatal. The relevant supply fuses should, therefore, be removed and kept in a safe place until the work is completed so that other persons cannot replace them unnoticed.
- Local safety regulations must be observed. Only technically qualified and appropriately trained personnel are authorised to install the meters.
- Only appropriate tools shall be used for the job. This means, e.g. that the screwdriver must be of the correct size for the screws, and the handle of the screwdriver must be insulated.
- The meters must be held securely during installation. They can cause injuries if dropped.
- Meters that have been dropped must not be installed, even if no damage is apparent, but must be returned to the service and repair department (or the manufacturer) for testing. Internal damage may result in malfunctions or short-circuits.
- The meters must never be cleaned under running water or with compressed air. Water ingress can cause short-circuits.

## 1.4 Radio Interference



### **Possible radio interference in residential environments**

This meter is normally a class B product. In combination with some communication modules it can become a Class A product. In a domestic environment, this may then cause radio interference, in which case the user may be required to take adequate measures.

---

## 2 Device description

This section provides you with a brief overview of the design and function of the E650 ZMD300AT/CT meters.

### 2.1 Field of application

ZMD300xT meters can be used for direct connection at the low voltage level. They are primarily used by medium consumers.

ZMD300xT meters have a comprehensive tariff structure. This extends from seasonal tariffs to multiple energy and demand tariff rates.

The ZMD300CT combi-meters record active and reactive energy consumption, the ZMD300AT active energy meters only the active energy in three-phase four-wire networks on low voltage, and from this determine the required electrical measured quantities. They are connected directly to the phase conductors at the measuring point.

The data determined are displayed (LCD) and are also available at the optical interface for data acquisition, with an appropriate communication unit also as required via CS, RS232, RS485, PSTN modem, GSM modem, etc. When equipped with transmitting contacts, the meters can also be used as transmitting meters for telemetering. The tariff rates can be controlled internally or externally.

With a communication unit, the meters can also be used for recording counter pulses for other physical media (e.g. water or gas volumes).

### 2.2 Characteristics

ZMD300xT meters have the following basic characteristics:

- Recording of active, reactive and apparent energy in all four quadrants (ZMD300CT) or recording of imported and exported active energy (ZxD 300AT)
- Tariff system with energy and demand tariff rates, stored values, load profiles, etc.
- Extended functions such as monitoring functions, sliding maximum demand, etc. (for ZMD300CT additionally power factor  $\cos\varphi$ )
- Tariff control
  - External
    - via control inputs (ZMD300xT21 and ZMD300xT41)
    - via communication interfaces using formatted commands
  - Internal
    - by integral time switch (ZMD300xT24 and ZMD300xT44)
    - by event signals based on monitored values, such as voltage, current demand, etc.
- Display of data on a liquid crystal display (LCD)
- Active and reactive power per phase and true RMS values of voltages and currents by means of digital signal processing (DSP) chips
- Accuracy: Compliance with IEC class 1 and with MID accuracy class B for active energy consumption (ZMD310xT) and IEC class 1 for reactive energy (ZMD310CT).



- Flexible measuring system through parameterisation (definition of different variables by software)
- Correct measurement even with failure of individual phases, or when used in two- or single-phase networks
- Wide range of measurement from starting current to maximum current
- Optical interface according to IEC 62056-21 and DLMS
  - For direct readout of meter data
  - For service functions of the meter, extension board and communication unit (e.g. parameterisation)
- Inputs for recording fixed valency pulses (communication unit)
- Output contacts (solid-state relays) for fixed valency pulses, control signals and status messages
- Output contacts (relays) for control and status messages
- Installation aids
  - Indication of phase voltages, phase angles, rotating field and direction of energy
- Storage of event information, e.g. voltage failures, exceeding of thresholds or error messages. Event information can be read out via the available interfaces. Important events can be communicated to the energy supply company as operational messages (sending of SMS messages, control of an arrow in the display, drive for an output contact, etc.).
- Interfaces such as CS, RS232, RS485, modem, etc. for remote transmission of data (communication unit)
- Auxiliary power supply for communication with the meter if no measuring voltage is present

## 2.3 Type designation

	ZMD	3	10	C	T	44	4207	S3
<b>Network type</b>	_____							
ZMD	3-phase, 4-wire network (M-circuit)							
<b>Connection type</b>	_____							
3:	Direct connection							
<b>Accuracy class</b>	_____							
10:	Active energy class 1 (IEC), B (MID)							
<b>Measured quantities</b>	_____							
C:	Active and reactive energy							
A:	Active energy							
<b>Construction</b>	_____							
T:	With exchangeable communication units							
<b>Tariffication</b>	_____							
21:	Energy rates, external rate control via control inputs							
24:	Energy rates, internal rate control via time switch (additionally possible via control inputs)							
41:	Energy and demand rates, external rate control via control inputs							
44:	Energy and demand rates, internal rate control via time switch (additionally possible via control inputs)							
	All versions with 3 control inputs and 2 output contacts							
<b>Additional functions</b>	_____							
000x	No extension board							
060x	6 outputs							
240x	2 control inputs, 4 outputs							
326x	3 control inputs, 2 relays outputs, auxiliary power supply 12–24 VDC							
420x	4 control inputs, 2 outputs							
045x	4 outputs, auxiliary power supply 100–240 VAC/VDC							
046x	4 outputs, auxiliary power supply 12–24 VDC							
047x	4 outputs, auxiliary power supply 12–60 VDC							
xxx0	No additional functions							
xxx2	DC magnet detection							
xxx7	Load profile							
xxx9	DC magnet detection and load profile (integrated terminal cover switch option only available in this configuration)							
<b>Series 3</b>	_____							

The communication unit is not a part of this type designation, since it is a complete unit in itself. Users can change it at any time without opening the certification seal. Every communication unit has its own user manual.

### Series designation

The hardware version is distinguished by the series designation. The 1st hardware generation (Series 1) has no series designation.

The 2nd hardware generation (Series 2) the series designation 'S2' is printed on the nameplate directly after the type designation. With meters which contain a measurement sensor with embedded coil, the series designation 'S2a' is used for distinction. 'S2s' represents a Series 2 meter with symmetrical terminal layout.

'S3' represents the newest hardware generation.

## Firmware version

The firmware version and firmware checksum stored in the meter can be shown on the display or read out as IEC readout list, if parameterised accordingly (see section 5.7 "Data readout"). Specific meter characteristics are present or not depending on the firmware version.

## 2.4 Block schematic diagram

This section provides an overview of the function of ZMD300xT meters based on a block schematic diagram.

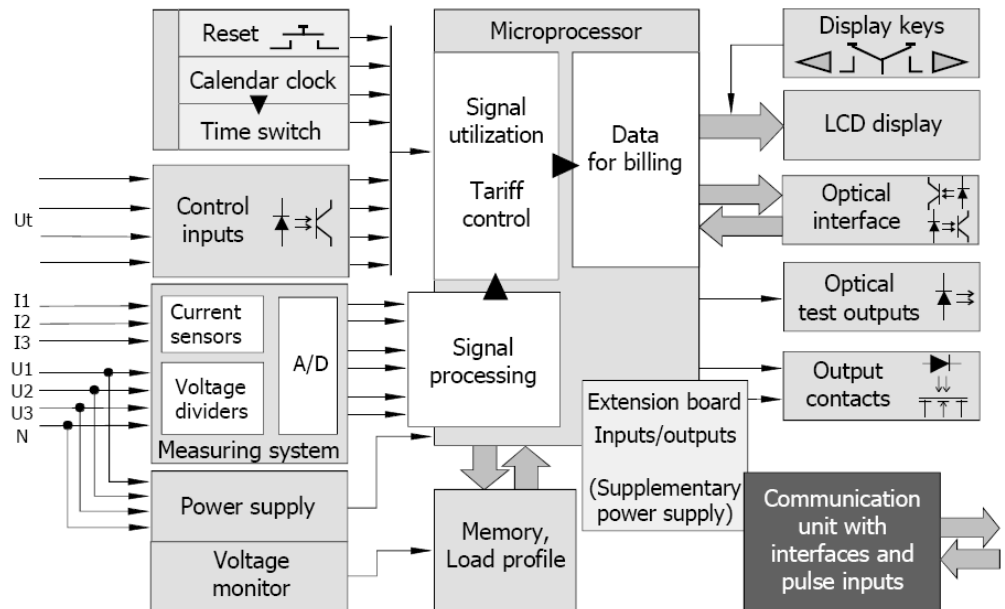

Figure 1. Block schematic diagram ZMD300xT

The ZMD300AT active energy meters record the imported and exported active energy consumption, while the ZMD300CT combi-meters record the active and reactive energy consumption in all four quadrants.

The ZMD300xT meters can be fitted with modular communication interfaces in a communication unit, which can be exchanged or used in the field as required.

## Inputs

The main meter inputs are:

- Connections of phase voltages (U1, U2, U3), phase currents (I1, I2, I3) and neutral conductor (N)
  - For processing in the measuring system
  - For the three-phase power supply to the meter and voltage monitor
- Control inputs  $U_t$  (3 fixed, plus up to 4 others on extension board) for:
  - Changeover of energy and demand tariff rates
  - Resetting
  - Demand inhibition
  - Synchronising

Opto-couplers protect the internal circuitry from interference, which could otherwise enter via the control inputs.

- Buttons
  - For display control (display buttons, optical interface)
  - For resetting or service functions (reset button)

- Pulse inputs for connection of external pulse transmitters (only for meters equipped with a communication unit)

## Outputs

The meter has the following outputs:

- LCD display with buttons for local reading of billing data (single 8-digit display with additional information, such as energy direction, energy type, presence of phase voltages and identification number)
- Optical test outputs (red, 1 in active energy meters, 2 in combi-meters)
- Optional alert LED (red) to indicate alerts on the front face of the meter
- Static relay with freely parameterised signal assignment (2 fixed, plus up to 6 others on the extension board)
- Relay outputs with limited parameterised signal assignment due to limited life expectancy (up to 2 on the extension board)
- Optical interface for automatic local data acquisition by a suitable acquisition unit (handheld terminal)
- Communication interfaces of various kinds in the communication unit (also see section 2.7 "Communication" )

## Measuring system

The input circuits (voltage dividers and current shunts with voltage transformer) record voltage and current in the individual phases. Analogue-digital converters digitise these values and feed them as instantaneous digital values via calibration stages to a signal processor.

## Signal processing

The signal processor determines the following measured quantities from the instantaneous digital values of voltage and current for each phase and forms their mean value over one second:

- Active power per phase
- Reactive power per phase (combi-meters ZMD300CT only)
- Phase voltages
- Phase currents
- Network (mains) frequency
- Phase angles

## Signal utilisation

For signal utilisation in the various registers, the microprocessor scans the measured quantities every second to determine the following values:

- Active energy (sum and individual phases, separated according to energy direction, if required in the combi-meters ZMD300CT also assigned to the 4 quadrants)
- Reactive energy (only for combi-meters ZMD300CT, sum and individual phases, separated according to energy direction, assigned to the 4 quadrants)
- Apparent energy (only for combi-meters ZMD300CT, sum and individual phases, separated according to energy direction)
- Power factor  $\cos\varphi$  (only for combi-meters ZMD300CT, individual phases and mean value)
- Phase voltages
- Phase currents and neutral current

- Active and reactive power
- Direction of rotating field
- Total harmonic distortions of active energy, voltage and current

**Tariff control**

Rate control is performed:

- Externally via control inputs (3 fixed, plus up to 4 others on the extension board)
- Externally via communication interfaces using formatted commands
- Internally by time switch and calendar clock
- By event signals based on threshold values of the monitoring functions

**Data preparation for billing**

The following registers are available for evaluation of the individual measured values:

- 32 for energy rates
- 27 for total energy
- 10 for running mean demand values
- 24 for demand rates
- 2 for power factors  $\cos\varphi$  (combi-meters ZMD300CT only)
- Up to 41 diagnostic registers
- Others for values of voltage and current, network frequency and phase angles

**Memory**

A non-volatile flash memory serves to record data profiles and also contains the configuration and parameterisation data of the meter and secures the billing data against loss due to voltage failures.

**Power supply**

The supply voltages for the meter electronics are obtained from the three-phase network, whereby the phase voltage can vary over the entire voltage range without the supply voltage having to be adjusted. A voltage monitor ensures correct operation and reliable data recovery in the event of a power failure and correct restarting when the voltage is restored.

**Auxiliary power supply**

For medium or high-voltage applications in particular, the measuring voltage can be switched off. Since the meter normally obtains its supply from the measuring voltage, it is also switched off and cannot be read. The auxiliary power supply connected in parallel with the normal power supply ensures operation of the meter free from interruption, so that it can be read at any time. The auxiliary power supply is situated on an extension board.

**Extension board**

The extension board is fitted inside the meter and is secured by the certification seals. It cannot be exchanged. It can have the following components:

- Up to 4 control inputs in combination with
- Up to 6 output contacts (solid-state relays)
- Up to 2 relays outputs
- An auxiliary power supply

**Communication unit** The communication unit for fitting only in the ZMD300xT meters is a complete unit in its own case. If present, it is situated behind the front door, and is therefore secured by a utility seal and can be exchanged or inserted in the field if necessary. It contains:

- Communication interfaces as required for remote readout of the meter (e.g. CS, RS232, RS485, modem)
- Two signal inputs (S0 interfaces) for processing external pulse transmitters

## 2.5 Measuring system

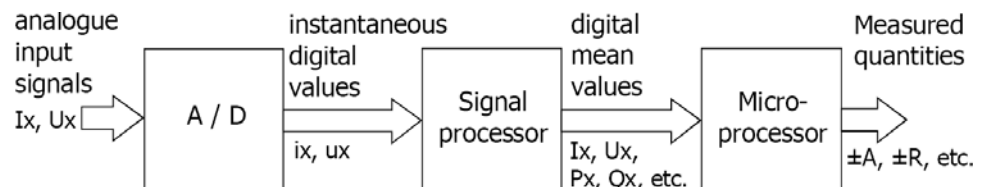

Figure 2. Block schematic diagram of measuring system

### 2.5.1 Input signals

The meter has the analogue current values  $I_1, I_2$  and  $I_3$  and analogue voltage values  $U_1, U_2$  and  $U_3$  available as input signals.

#### ZMD300xT

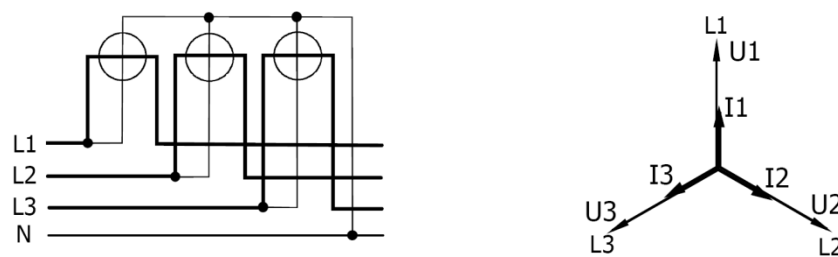

Figure 3. Type of measurement ZMD300xT

Since the ZMD300xT measures the individual phases mutually independently with one measuring element each, it can record the sum of the three phases, the individual phases themselves, the phase angle between voltage and current as well as the angle between voltages  $U_1-U_2$  and  $U_1-U_3$ .

**Voltage input** High resistance voltage dividers reduce the voltages  $U_1, U_2$  and  $U_3$  (58 to 240 V) applied to the meter to a proportionate amount of a few mV ( $U_U$ ) for further processing.

**Current input** Internal current transformers reduce the input currents  $I_1, I_2$  and  $I_3$  to the meter (0 to 10 A) for further processing. The secondary currents of these current transformers develop voltages proportional to the input currents across resistors, also of a few mV ( $U_I$ ).

## 2.5.2 Signal processor

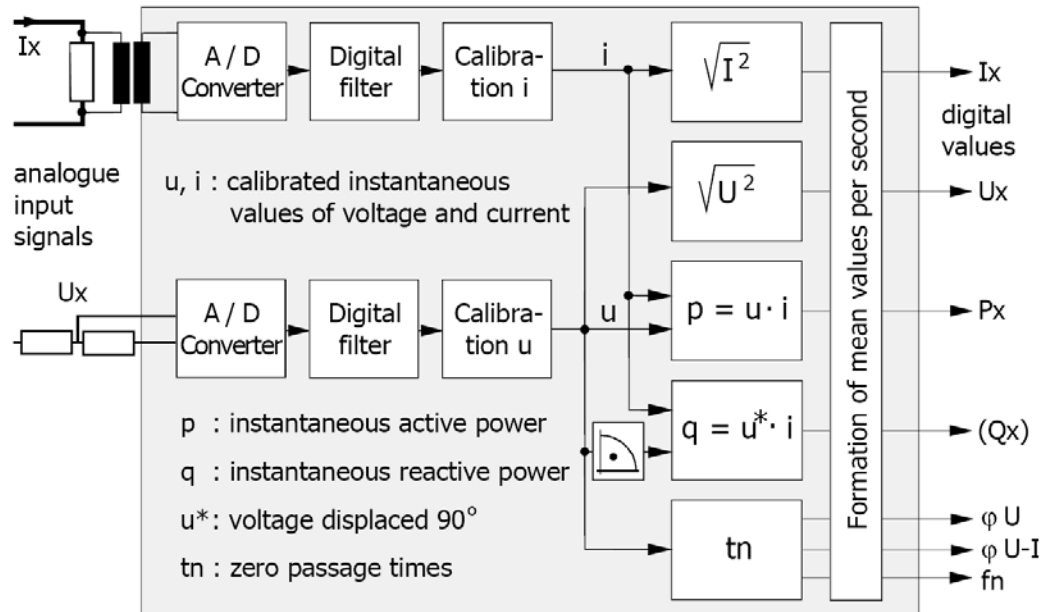

Figure 4. Principle of signal processor

ZMD300AT active energy meters do not measure reactive energy.

### Digitizing

The analogue signals  $U_x$  and  $I_x$  are digitised in Sigma-Delta converters (analogue-digital converters with highest resolution) with a sample rate of 1.6 kHz and then filtered. A following calibration stage compensates for the natural errors of the voltage divider or current transformer, so that no further adjustment is necessary in the subsequent processing.

Calibrated digital instantaneous values of voltage ( $u$ ) and current ( $i$ ) for all three phases are then available as intermediate values for the formation of the required values in the signal processor.

### Calculation of active power

The instantaneous value of active power  $p$  is produced by multiplying the instantaneous values of voltage  $u$  and current  $i$  (the active component corresponds to the product of voltage component with the current component parallel to the voltage). Thereby the harmonics up to 1 kHz are measured correctly.

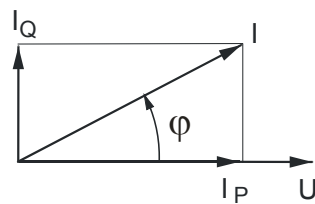

Calculation per phase of  
 $P = U \cdot I \cdot \cos\varphi$

Figure 5. Active power calculation

### Instantaneous power with sign

If the meter is parameterised to calculate instantaneous power as signed values, the following values of power are available:

Active P: + in QI and QIV, - in QII and QIII

Reactive P: + in QI and QII, - in QIII and QIV

### Calculation of reactive power

There are two possibilities to calculate the instantaneous value of reactive power (ZxD300Cx combi-meters only):

#### Measured:

For the instantaneous value of reactive power  $q$  the instantaneous value of voltage  $u$  must be rotated by  $90^\circ$  before multiplication (the reactive

component is the product of the voltage component with the current component vertical to the voltage). Thereby no harmonics are measured since only the fundamental wave is rotated through 90°.

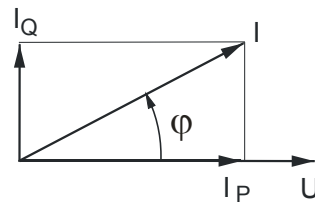

Calculation per phase of  
 $Q = U \cdot I \cdot \sin\varphi$

Figure 6. Reactive power calculation (method: measured)

#### Calculated vectorial (not recommended):

The instantaneous value of reactive power is calculated using the values of active power and apparent power.

The reactive power is the square root of the square value of apparent power minus the square value of active power. This method includes the harmonics.

$$Q = \sqrt{S^2 - P^2}$$

#### $U_{RMS}$ , $I_{RMS}$ calculation

The square values of voltage and current are obtained by multiplying the instantaneous values of voltage and current by themselves. From these values the signal processor forms the corresponding single-phase RMS values  $U_{RMS}$  and  $I_{RMS}$ .

#### Time measurement

The network frequency can be calculated from the time measured between two zero passages (change from negative to positive value of voltage  $U_1$ ). The times between zero passage of the phase voltage  $U_1$  and those of the other phase voltages  $U_2$  and  $U_3$  serves to determine the phase angle between the voltages and of the rotating field.

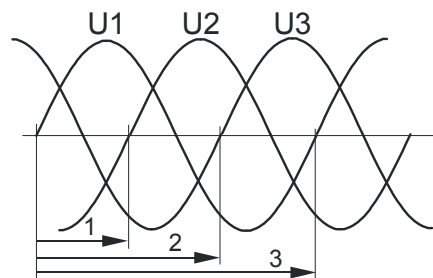

Time measurement  
for rotating field,  
frequency, phase angle

- 1 :  $T_{U1-U2}$
- 2 :  $T_{U1-U3}$
- 3 :  $T_{U1-U1}$  (fn)

Figure 7. Time measurement

The phase angle between voltage and current is determined by the times between zero passage of the phase voltage  $U_1$  and those of the phase currents  $I_1$ ,  $I_2$  and  $I_3$ .

#### Mean value formation

For further processing of the individual signal, the signal processor generates mean values over one second, which the following microprocessor scans at intervals of one second.



### 2.5.3 Measured quantities

Measured quantity		ZMD300
Active energy in quadrant I	A (QI)	Sum / Phases
Active energy in quadrant II	A (QII)	Sum / Phases
Active energy in quadrant III	A (QIII)	Sum / Phases
Active energy in quadrant IV	A (QIV)	Sum / Phases
Active energy import	+A (QI+QIV)	Sum / Phases
Active energy export	-A (QII+QIII)	Sum / Phases
Active energy, absolute value	+A + -A	Sum / Phases
Active energy, absolute value	+A - -A	Sum / Phases
Active energy import summation	$\Sigma +A$	Sum
Active energy export summation	$\Sigma -A$	Sum
Active energy by single quantity	$\Sigma  ALx $	Sum
Reactive energy in quadrant I	R (QI)	Sum / Phases
Reactive energy in quadrant II	R (QII)	Sum / Phases
Reactive energy in quadrant III	R (QIII)	Sum / Phases
Reactive energy in quadrant IV	R (QIV)	Sum / Phases
Reactive energy import	+R (QI+QII)	Sum / Phases
Reactive energy export	-R (QIII+QIV)	Sum / Phases
Reactive energy import	+R (QI+QIV)	Sum / Phases
Reactive energy export	-R (QII+QIII)	Sum / Phases
Reactive energy, combined	R (QI+QIII)	Sum / Phases
Reactive energy, combined	R (QII+QIV)	Sum / Phases
Reactive energy, absolute value	+R + -R	Sum / Phases
Reactive energy, absolute value	+R - -R	Sum / Phases
Reactive energy import summation	$\Sigma +R$	Sum
Reactive energy export summation	$\Sigma -R$	Sum
Apparent energy import	+S (QI+QIV)	Sum / Phases
Apparent energy export	-S (QII+QIII)	Sum / Phases
Phase voltages (RMS)		U1, U2, U3
Phase currents (RMS)		I1, I2, I3
Neutral current	I0	yes
Network frequency	$f_n$	yes
Active power	$\pm P$	Sum / Phases
Reactive power	$\pm Q$	Sum / Phases
Phase angle between voltages	$\varphi_U$	U1-U2 / U1-U3*
Phase angle between voltage and current	$\varphi_{U-I}$	U1-I1, U1-I2, U1-I3 * or U1-I1, U2-I2, U3-I3
Power factor	PF	Sum / Phases
Direction of rotating field		yes

Measured quantity		ZMD300
THD of active energy import	+THD <sub>A</sub>	Sum
THD of active energy export	-THD <sub>A</sub>	Sum
THD of active energy (percent)	THD <sub>A</sub> [%]	Sum
THD of phase voltages (absolute)	THD <sub>U</sub>	Phase 1, 2, 3
THD of voltage (percent)	THD <sub>U</sub> [%]	Sum
THD of phase currents (absolute)	THD <sub>I</sub>	Phase 1, 2, 3
THD of current (percent)	THD <sub>I</sub> [%]	Sum

\* Only if U1 is present.

## 2.5.4 Formation of measured quantities

By scanning the mean values of active power P, and in combi-meters also reactive power Q every second, energy components are produced (Ws or vars) at fixed intervals (every second) and with varying energy magnitudes or demand. These energy components are scaled by the microprocessor corresponding to the meter constant and are then available as measured quantities for selection of the measured values. The measured values are fed directly to the following registers to record the energy and the maximum demand (in combi-meters also of minimum power factor).

### Active energy

The active energy in the individual phases  $\pm A1$ ,  $\pm A2$  and  $\pm A3$  are formed directly from the mean values of active power P1, P2 and P3.

By summing the mean values of active energy A1, A2 and A3 the microprocessor calculates the total active energy import +A or the total active energy export -A.

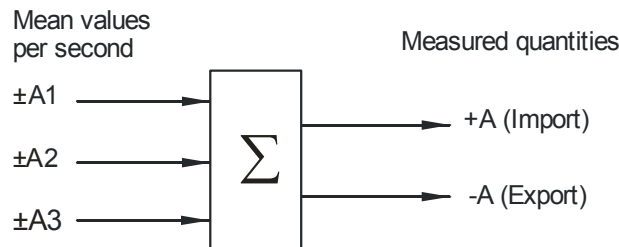

Figure 8. Total active energy

### Reactive energy

The reactive energy values of the individual phases  $\pm R1$ ,  $\pm R2$  and  $\pm R3$  are obtained in the combi-meters directly from the mean values of reactive power Q1, Q2 and Q3. The reactive energy can therefore also be calculated vectorially (see 1.5.2).

By summing the mean values of reactive energy R1, R2 and R3, the microprocessor calculates the total positive reactive energy +R or the total negative reactive energy -R.

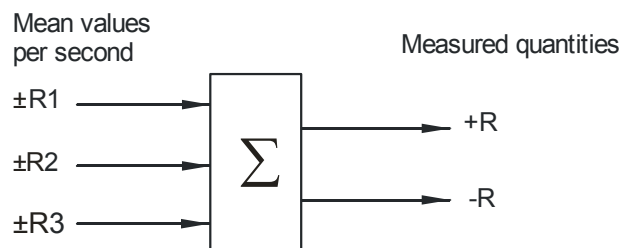

Figure 9. Total reactive energy

The microprocessor can allocate the reactive energy to the 4 quadrants in the combi-meters from the signs of R and A:

- Reactive energy in 1st quadrant: +Ri
- Reactive energy in 2nd quadrant: +Rc
- Reactive energy in 3rd quadrant: -Ri
- Reactive energy in 4th quadrant: -Rc

In the same way, it can allocate the reactive energy of the individual phases to the 4 quadrants.

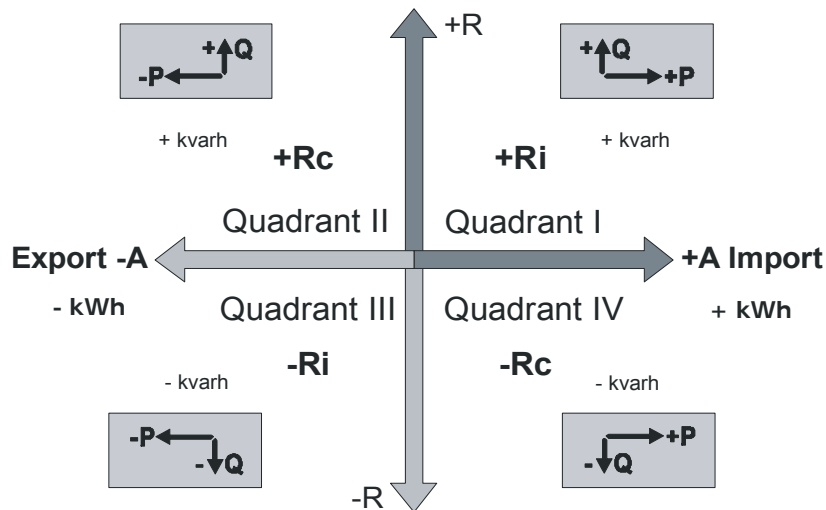

Figure 10. 4-quadrant measurement

The quadrants are numbered from top right as 1st quadrant (+A/+Ri) anti-clockwise to the 4th quadrant (+A/-Rc) at bottom right.

**Apparent energy**

The apparent energy is calculated in the combi-meters in two ways:

- By vectorial addition of the active and reactive energy of the individual phases
- By multiplying the rms values of voltage and current of the individual phases

The method of calculation can be parameterised (only one possible in each case).

**Calculation method 1 (vectorial addition)**

From the mean values A1, A2 and A3 and R1, R2 and R3 the microprocessor calculates the apparent energy of the individual phases ±S1, ±S2 and ±S3 as well as the total apparent energy ±S.

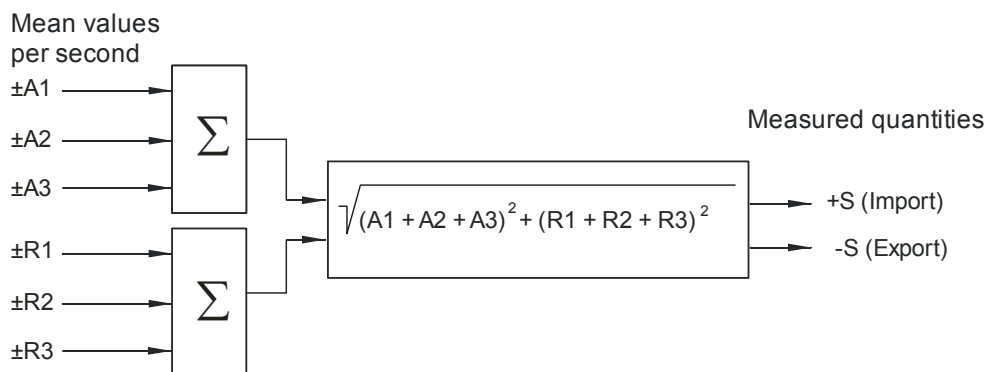

Figure 11. Total apparent energy according to calculation method 1



**Only fundamental wave considered for reactive energy**

Only the fundamental wave is considered for the calculation of the reactive energy share; possible harmonics are not taken into account.

**Calculation method 2 (from rms values)**

From the mean values  $U1_{rms}$ ,  $U2_{rms}$ ,  $U3_{rms}$  and  $I1_{rms}$ ,  $I2_{rms}$ ,  $I3_{rms}$  the microprocessor calculates by multiplication the apparent power of the individual phases  $\pm VA1$ ,  $\pm VA2$  and  $\pm VA3$  and summates these for the total apparent power  $\pm VA$ .

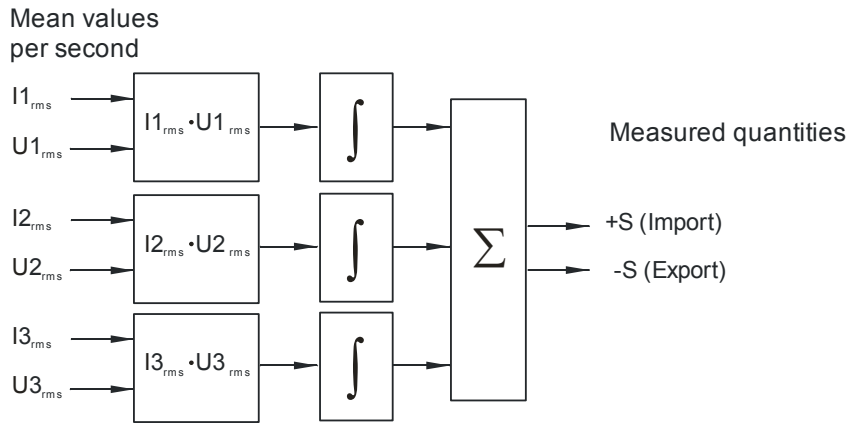

Figure 12. Total apparent power according to calculation method 2 (ZxD300Cx combi-meters only)



**Harmonics considered for reactive energy**

As RMS values are used for the calculation of the apparent energy with calculation method 2, not only the fundamental wave but also the harmonics are taken into account. Therefore, if harmonics are present, the measured values are greater than those of calculation method 1.

**Summation channels**

The values of two measurement quantities (incl. pulse inputs EX1 and EX2) can be added.

**Power factor  $\cos\phi$**

The power factor  $\cos\phi$  is calculated in combi-meters as follows:

$$\cos\phi = \frac{P}{S}$$

The meter uses the method of calculation employed for calculating the apparent power.

**Phase voltages**

The rms values of the voltages  $U1_{rms}$ ,  $U2_{rms}$  and  $U3_{rms}$  are obtained from the mean values of the squares of the voltages by extracting the root and directly from these the phase voltages U1, U2 and U3.

**Phase currents**

The rms values of the currents  $I1_{rms}$ ,  $I2_{rms}$  and  $I3_{rms}$  are obtained from the mean values of the squares of the currents by extracting the root and directly from these the phase currents I1, I2 and I3.

**Neutral current**

The signal processor calculates the instantaneous neutral current  $i_0$  by adding the instantaneous phase currents  $i_1$ ,  $i_2$  and  $i_3$ .

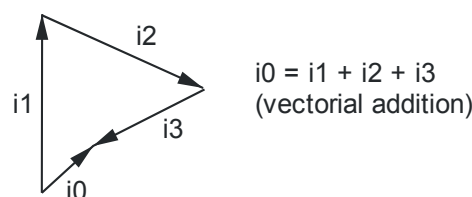

Figure 13. Neutral current  $i_0$

**Network frequency**

The signal processor calculates the network frequency  $f_n$  by forming the reciprocal from the time  $t_{U1-U1}$  between two zero passages of voltage U1.

**Phase angles**

The signal processor calculates the phase angles between voltages U1-U2 and U1-U3 from the times  $t_{U1-U1}$ ,  $t_{U1-U2}$  and  $t_{U1-U3}$  between zero passages of the various voltages.

The signal processor calculates the phase angle between voltage U1 and current per phase from the times  $t_{U1-I1}$ ,  $t_{U1-I2}$  and  $t_{U1-I3}$  between zero passages of the voltage U1 and the phase currents.

2 forms of representation are available for displaying the phase angle. These can be selected by parameterisation.

**Case 1:** All voltage and current angles are displayed clockwise with reference to the voltage in phase 1. The values of the angles are always positive and can be from 0 to 360°.

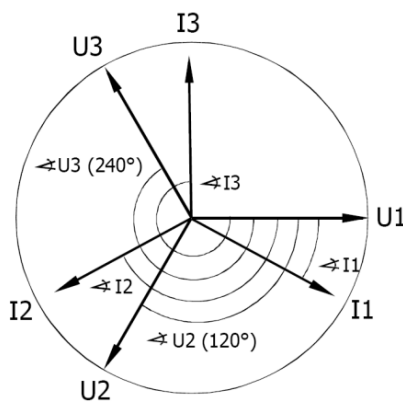

Figure 14. Phase angle case 1

**Case 2:** The voltage angles are displayed as in case 1. The angles of the currents are displayed, however, with reference to the associated phase voltage and can have values between -180° and +180°.

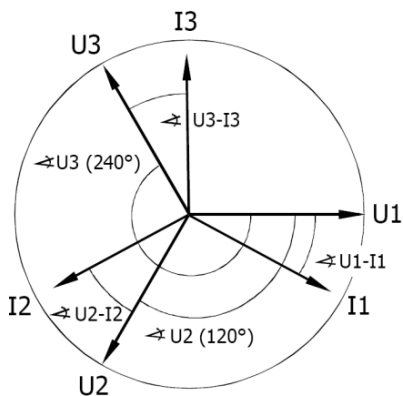

Figure 15. Phase angle case 2

**Direction of rotating field**

The direction of the rotating field is calculated by the microprocessor based on the phase angle of the 3 voltages. If the direction of rotation corresponds to that specified by the parameterisation, the phase voltage indications L1, L2 and L3 are continuously lit. Otherwise they flash every second.

**Total harmonic distortion**

The measuring system produces information about the total harmonic distortion of the active energy.

For that purpose, the voltages are fed through notch filters, which remove

the fundamental wave.

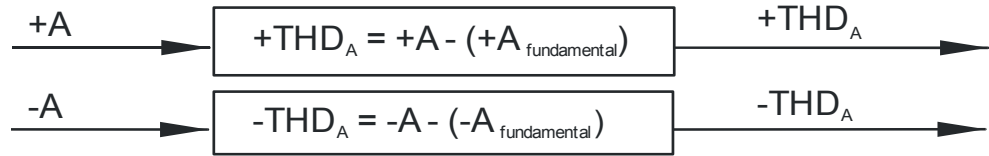

Figure 16. Calculation of total harmonic distortion

In addition, the following absolute and relative THD values are available:

- THD of active energy (relative to the nominal active energy)
- THD of phase voltages (absolute)
- THD of voltage (relative to the nominal voltage)
- THD of phase currents (absolute)
- THD of phase current (relative to the nominal current)

## 2.5.5 Summation channels

The values of two measurement quantities (incl. pulse inputs EX1 and EX2) can be added. The added quantities must be of the same energy type (active, reactive or apparent). The sum is stored in a total energy register.

Energy registers which contain the summation of two measured quantities (summation channels) cannot be used for tariffication.

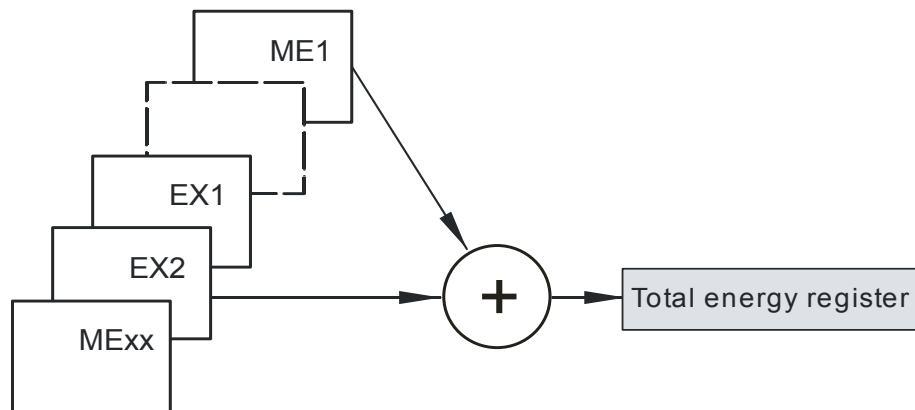

Figure 17. Summation channels

## 2.6 Data profile

A non-volatile memory (FLASH memory) contains the data of:

- The stored value profile
- The load profile 1
- The load profile 2 (optional)
- The event log
- The three groups of dedicated event logs

The flash memory stores data without data loss in case of voltage failures. No battery is required for this purpose.

The total size of the available memory for the stored billing value profile, the load profile(s), the event log and the dedicated event logs is 1.8 MB.

### 2.6.1 Stored value profile

At the end of the billing period, the meter stores the current value of the registers to the stored value profile. Which energy registers and/or demand registers are stored to the stored billing value profile can be selected by parameterisation.

**Memory organisation** The stored value profile is organised as a circular buffer, i.e. the oldest entry will be overwritten by the most recent entry. The memory capacity which is available for the stored value profile depends on parameterisation.

### 2.6.2 Load profile 1 and load profile 2 (option)

The load profiles are used to save the values of various registers at regular intervals. The measured values that are captured in the load profile can be selected by parameterisation.



#### Load profile 2 is optional

The second load profile is optional.  
Please consult your sales representative for further details.

---

**Profile 1** The first load profile is generally used for billing purposes. Its capture period has a range of 1...60 min. This load profile may also contain instantaneous values and detailed status information for data processing in central stations.

**Profile 2** The second load profile can be used to store instantaneous values over a period which differs from the period of the first load profile. Apart from the differing capture period, the second load profile is identical with the first load profile.

**Memory organisation** The load profile is organised as a circular buffer, i.e. the oldest entry will be overwritten by the most recent entry. The memory capacity which is available for the load profile(s) depends on parameterisation. If both load profiles are activated, they share the memory capacity which is allocated to the load profile(s).

### 2.6.3 Event log

Events that occur sporadically are stored in the event log. The user may select which events trigger an entry in the event log. The event log is used to analyse the behaviour of the network as well as to supervise the correct function of the meter.

**Memory organisation** In the event log, a maximum of 500 event entries can be stored. The individual entries consist of the time stamp and the event number. Additional information such as the error register or energy total registers can also be stored with every event.

The event log is organised as a circular buffer, i.e. the oldest entry will be overwritten by the most recent entry.

**Dedicated event log** Network quality events, can be stored in the dedicated event log. The dedicated event log consists of three groups of logs.

- Over-voltage events
- Under-voltage events
- Missing voltage events

In the dedicated event logs, important information can be stored per entry such as:

- Duration of the events
- Extreme values of the events (not for missing voltage).
- Instantaneous values
- Maximum three energy registers

Additional information can be read from the header of the event logs, such as the longest entry, the shortest entry, the total number of occurrence and the total duration of the event.

### Memory organisation

The dedicated event logs are organised as circular buffers, i.e. the oldest entry will be overwritten by the most recent entry.

### List of events

The table below lists all events which can be captured in the event log. Depending on the parameterisation, some events may never occur.

Events which can be stored in the dedicated event log are marked in the corresponding column.

Number	Event	Entry in dedicated event log possible
2	All energy registers cleared	
3	Stored values and/or load profile cleared	
4	Event log profile cleared	
5	Battery voltage low	
7	Battery ok	
8	Billing period reset	
9	Daylight saving time enabled or disabled	
10	Clock adjusted (old time/date)	
11	Clock adjusted (new time/date)	
17	Under-voltage L1	x
18	Under-voltage L2	x
19	Under-voltage L3	x
20	Over-voltage L1	x
21	Over-voltage L2	x
22	Over-voltage L3	x
23	Power down	
24	Power up	
25	Over-current L1	
26	Over-current L2	
27	Over-current L3	
28	Over-current neutral	
31	Power factor monitor 1	
32	Power factor monitor 2	
33-40	Demand monitors 1-8	
45	Error register cleared	



Number	Event	Entry in dedicated event log possible
49	Missing voltage L1	x
50	Missing voltage L2	x
51	Missing voltage L3	x
55	Current without voltage L1	
56	Current without voltage L2	
57	Current without voltage L3	
58	Missing additional power supply	
59	All registers and profiles cleared	
63	Wrong phase sequence	
64	Correct phase sequence	
66	Invalid clock	
74	Backup memory access error	
75	Measuring system access error	
76	Time device access error	
77	Load profile memory access error	
79	Communication unit access error	
80	Display board access error	
81	Program checksum error	
82	Backup data checksum error	
83	Parameter checksum error	
84	Load profile checksum error	
85	Stored values checksum error	
86	Event log checksum error	
87	Calibration data checksum error	
88	Load profile 2 checksum error	
89	Invalid start-up sequence	
93	Expired watchdog (general system error)	
94	Communication locked	
96	Wrong extension board identification	
104	Count registers cleared	
105	SMS delivery to GSM failed	
106	Alert occurred	
124	Compensation values changed	
128	Energy total and rate register cleared	
133	Terminal cover removed	
134	DC Field detected ON	
187	Terminal cover mounted	
188	DC Field detected OFF	
193	Load profile 2 cleared	

Number	Event	Entry in dedicated event log possible
211	Control input 1 set	
212	Control input 1 reset	

## 2.7 Communication

The ZMD300xT meters have an optical interface for local communication via a readout head, and a wide range of communication interfaces which can be inserted in the meter.

### 2.7.1 Optical interface

The optical interface to IEC 62056-21 is a serial, bi-directional interface. It is situated at top right on the main faceplate (also see section 3 "Mechanical construction") and serves:

- For automatic local data recording by means of a suitable acquisition unit (hand-held terminal) (see section 5.7 "Data readout")
- For performing service functions, e.g. to input formatted commands (see section 5.8 "Input of formatted commands")
- As "optical button", i.e. as receiver of a light signal, e.g. generated by a flashlight acting like the "down" display button (also see section 5.2.2 "Control of display via optical interface")
- For communication with a Landis+Gyr .MAP110 Service Tool or a Landis+Gyr MAP120 Parameterisation Tool.

### 2.7.2 Communication units

The communication units which can be inserted in the meter can be used:

- For **remote reading** and for **remote tariff control** of meters (RS232, RS485, CS, M-Bus, PSTN modem, GSM modem, GPRS modem, Ethernet, etc.) or
- For **recording metering pulses** for other physical media, such as water, gas or heat (S0 interface).

Access via the communication interfaces is protected for specific access levels using the meter security system by means of passwords. If the monitoring is activated by corresponding parameterisation, communication is inhibited for a selected time (max. 24 h) after a selected number of password attempts with an incorrect password (max. 15). Monitoring takes place independent of all access levels with password protection and for the IEC W5 password.

The communication devices are accommodated in an easily exchanged communication unit, which is plugged in behind the front door of the meter and secured by a factory seal (also see section 3 "Mechanical construction"). It can be fitted and removed at any time in the field without touching the certification seal. Landis+Gyr recommend exchanging communication units only if the meter is separated from the network and switched off.

An initial fitting as well as retrofitting without re-parameterisation of the meters is possible with any version of communication unit. For fitting and removal of the already parameterised communication units, the installation personnel do not require any special knowledge of communications.

Modern plug connections ensure a rapid and faultless connection of the communication units.

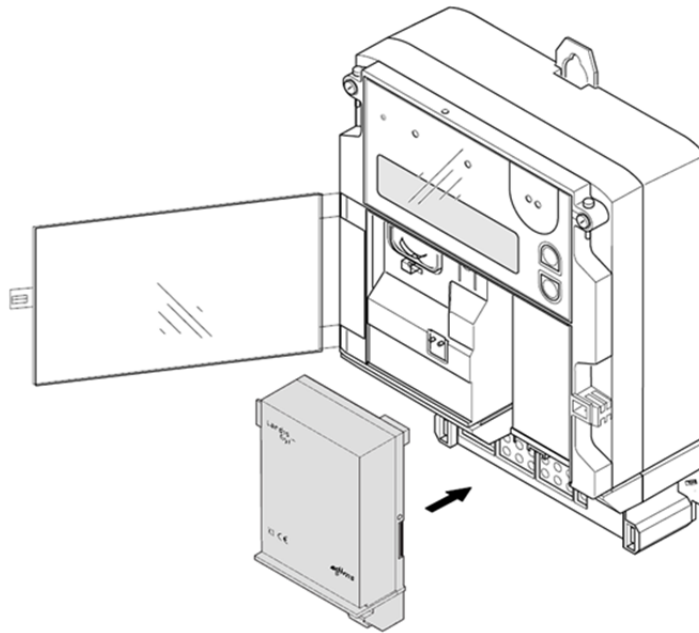

Figure 18. Simple fitting of the communication unit

### Versions of communication units

Communication units (CU) are available in various versions. The document "Overview of Communication Applications", D000011226 contains a list of all currently available CU-interfaces with explanations.

### Further information sources

More detailed information about Landis+Gyr Dialog communication solutions can be found in the following documents.

- **Technical data** for the various communication units
- **User manuals** for the various communication units
- Detailed **application notes** for numerous reference applications with various communication units for different transmission media:
  - Point-to-point Connection with internal PSTN Modem Mx (D000011505)
  - Point-to-point Connection with internal GSM Modem Gx (D000011507)
  - Etc.

All these documents as well as advisory services are available from authorised Landis+Gyr representatives.

## 2.8 MAP software tools

There are two software tools available for parameterisation of the E650 meter and for communication with the meter: .MAP110 and MAP120

### Areas of application



Figure 19. Application of MAP software tools

**.MAP110**

The .MAP110 Service Tool covers the following applications normally required for meter installation and in the service sector:

- Billing data readout
- Readout and export of profiles (load profile(s), stored values and event log, dedicated event logs)
- TOU (Time of Use) readout and modification
- Billing period reset
- Register and profile resets
- Setting of certain parameter ranges, such as primary data, time switch, communication parameters, etc.
- Communication input settings
- Communication settings for Landis+Gyr communication units readout and modification
- GSM installation aid for Landis+Gyr communication units (field strength indicators, telephone number information, PIN-code handling)
- Test SMS message transmission
- Analysis and diagnostic functions

**MAP120**

The Landis+Gyr MAP120 software is used to parameterise the meter and the communication unit, i.e. it is possible to read out and modify all device parameters.

In contrast to communication devices from other manufacturers, no additional software and training costs are incurred by the use of Landis+Gyr communication units, since the MAP software tools support both meters and communication units.

## 2.9 Anti-tampering features

The following anti-tampering features are available for ZMD310xT meters:

- DC magnet detection for the detection of strong magnetic fields close to the meter. This feature is installed during the manufacturing process.
- Terminal cover detection for the detection of situations when the terminal cover has been opened. This feature can be a retrofit or an integrated version. The integrated version is available if the DC magnet detection option is selected and must be integrated during manufacturing process.
- Example of integrated terminal switch available from mid-2012.



### 2.9.1 DC magnet detection

The meters ZMD310xT can be ordered with a feature which detects strong DC magnetic fields. When a magnetic field is present, event 134 is set; when the magnetic field disappears, event 188 is set. These events can e.g. be entered into the event log with date and time. The meter's type description informs you whether this feature has been implemented (see page 10).

With the DC magnet detection, it is possible to order the integrated terminal cover detection option.

### 2.9.2 Terminal cover detection

Installed ZMD300 meters can be equipped with a terminal cover detection unit. For this, they need to be parameterised and the unit – consisting of a switch which detects the removal of the terminal cover – has to be installed.

Whenever the retrofit terminal cover is removed, it detects the switch status change via control input 1 and enters event 211 in the event log with date and time. When the terminal cover is mounted again, event 212 is entered in the event log with date and time.

Please order terminal cover detection units – part number 74 766 0163 0 (minimum order quantity 10) – from:

Landis+Gyr AG  
Service & Repair  
Theilerstrasse 1  
CH-6301 Zug  
Switzerland

For installation of the unit, see section 4.6 "Installation of terminal cover detection".

In case of the integrated terminal switch used, the event 133 is set when the terminal cover is removed and event 187 when the terminal cover is mounted.

## 3 Mechanical construction

This section describes the mechanical construction of the ZMD300xT meter and shows the most common connection diagrams.

### 3.1 Housing

The internal construction of the meters is not described here, since they are protected following calibration and official certification on delivery by a manufacturer and certification seal. It is not permitted to open the meters after delivery. The front door is only secured with a utility seal and can be opened to operate the reset button, to change the battery, to exchange the tariff faceplate with connection diagram, or to fit or remove a communication unit (see figure 21 and separate user manuals for the communication units available).

The following drawing shows the meter components visible from outside.

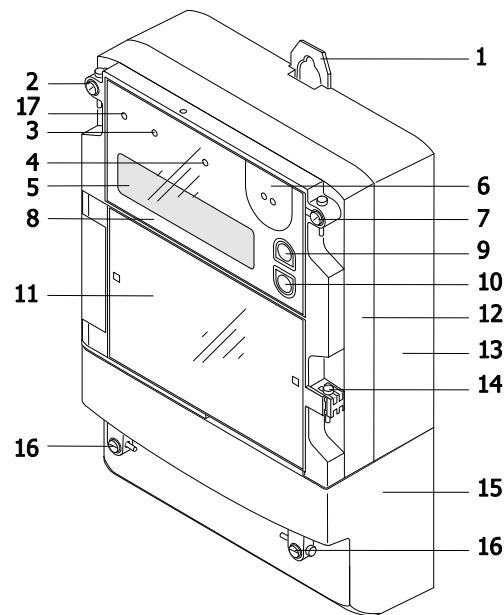

Figure 20. Meter ZMD300xT

1	Combined suspension hanger (open or concealed)	10	Display button "down"
2	Screw with manufacturer seal	11	Front door with tariff faceplate
3	Optical test output reactive energy consumption (red), ZMD300CT only	12	Upper part of case
4	Optical test output active energy consumption (red)	13	Lower part of case
5	Liquid crystal display (LCD)	14	Utility seal for front door
6	Optical interface	15	Terminal cover
7	Screw with certification seal	16	Terminal cover screws with plate utility seals
8	Front section with main faceplate	17	Alert LED (optional)
9	Display button "up"		

- Case** The meter case is made of antistatic plastic (polycarbonate). The upper part of the case is provided with two transparent plastic viewing windows, affording a view of the main faceplate (top) and the tariff faceplate (bottom). The lower part of the case is additionally glass-fibre reinforced.
- Viewing window** The upper viewing window with the main faceplate is secured on the upper right side with a certification seal, while the upper part of the case is secured on the upper left side with a manufacturer seal (warranty) or a second certification seal.
- The lower viewing window is in the form of a hinged front door, secured with a utility seal. The tariff faceplate with the connection diagram on the rear side, the battery compartment, the reset button and (if present) the communication unit are situated behind this front door.
- Terminal cover** The terminal cover is available in various lengths in order to ensure the required free space for the connections.
- Front door** The front door must be opened to give access to the battery compartment, reset button and tariff faceplate. To fit or remove the communication unit, the terminal cover must also be removed.

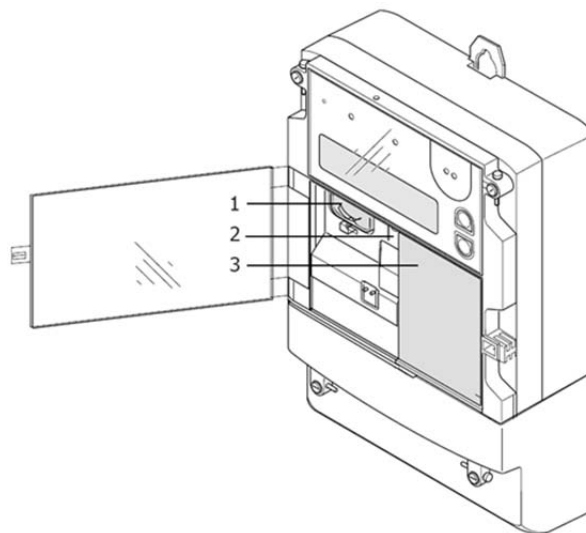

Figure 21. Meter with front door open

1	Battery compartment
2	Reset button R
3	Communication unit or dummy

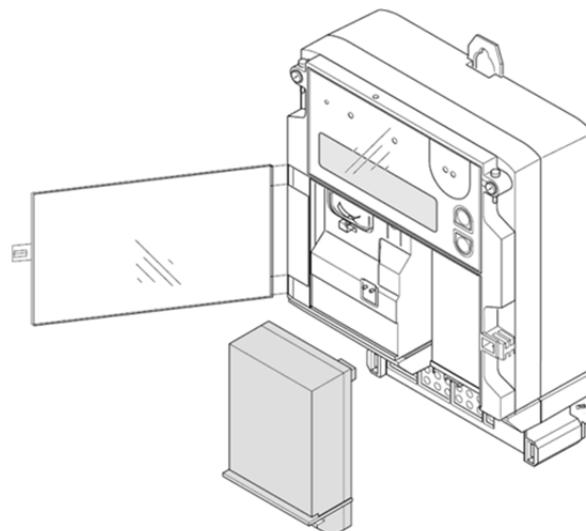

Figure 22. Meter with communication unit withdrawn

If the meter has no communication unit, this is replaced by a dummy case.

### Seal component

An additional component, which is easy to install, allows the use of a standard padlock instead of a utility seal.

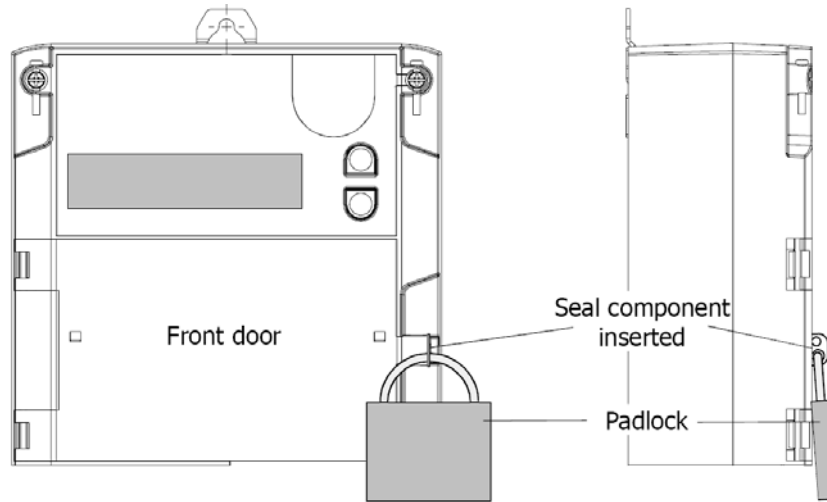

Figure 23. Front door sealing using a padlock

The seal component is stowed away in a holder under the front door when not in use.

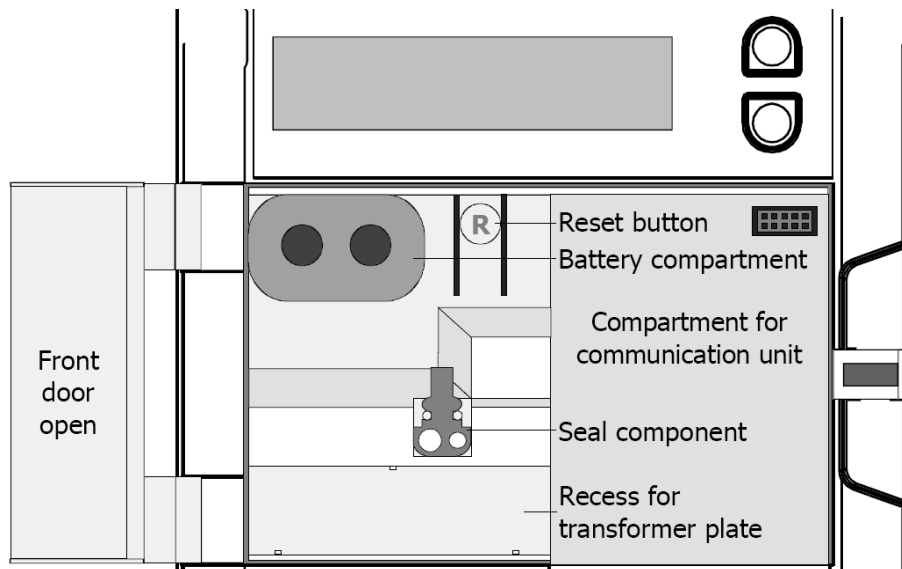

Figure 24. Stowage of seal component when not in use

The seal component is installed as follows:

- Slide the seal component into the vertical slot at an angle, as shown, (position 1) until it contacts the rear wall.
- Now turn the seal component until it is horizontal and slide it down into position 2 as illustrated. The two bulges firmly fix the seal component into the lateral grooves.



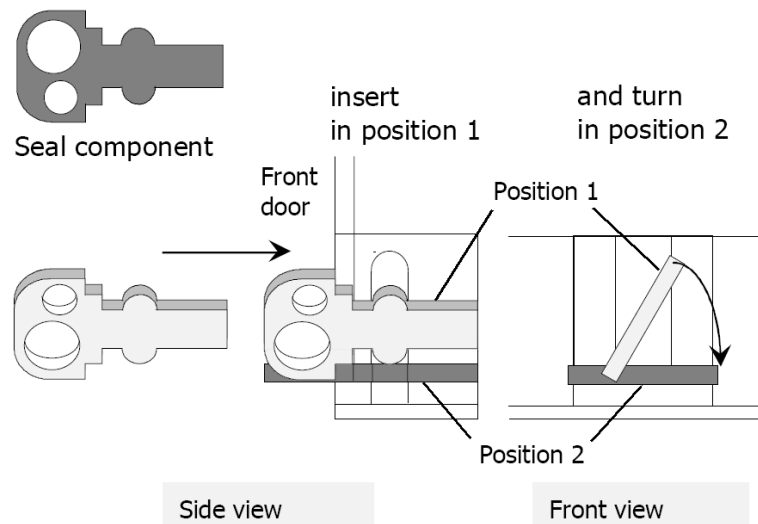

Figure 25. Seal component for use with padlock

## 3.2 Faceplates

The faceplate is divided into two parts and is designed to customer specifications. It contains all relevant data about the meter.

### Main faceplate

The main faceplate is situated behind the plastic viewing window, which is secured by a certification seal. Recesses permit operation of the display buttons "down" and "up" for control of the liquid crystal display.

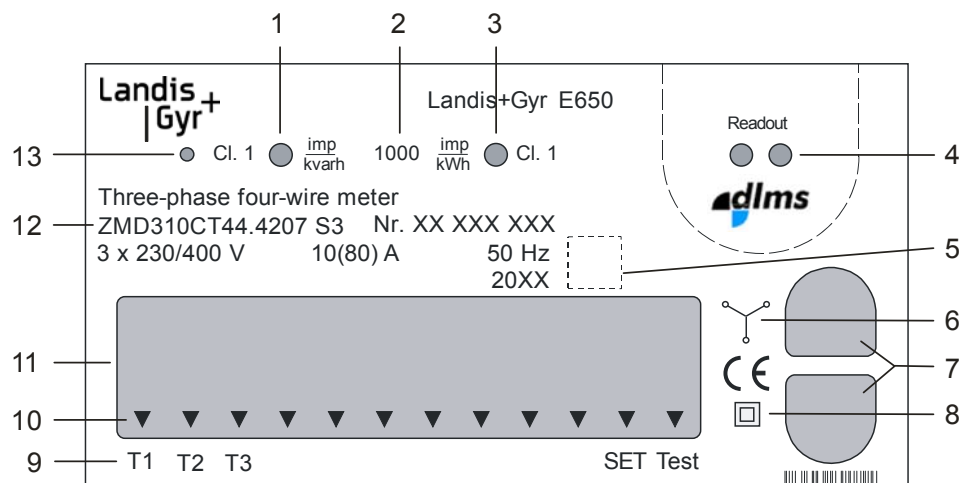

Figure 26. Main faceplate (example ZMD310CT)

- 1 Optical test output reactive energy (with accuracy class – ZMD300CT only)
- 2 Meter constant R1 (referred to primary values) or R2
- 3 Optical test output active energy (with accuracy class)
- 4 Optical interface
- 5 Approval symbol
- 6 Type of connection
- 7 Display button "up"/Display button "down"
- 8 Symbol for double protective insulation
- 9 Status indication
- 10 Arrows for present status indication
- 11 Liquid crystal display (LCD)
- 12 Meter data (type designation, serial number, rated values, year of construction)
- 13 Alert LED (optional)

The operating elements and displays are described more detailed in section 5 "Operation".

**Tariff faceplate**

The tariff faceplate is placed in the front door, which can be swung out sideways to the left and is secured by a utility seal. The connection diagram of the meter is shown on the back of the faceplate and is therefore visible with the front door open.

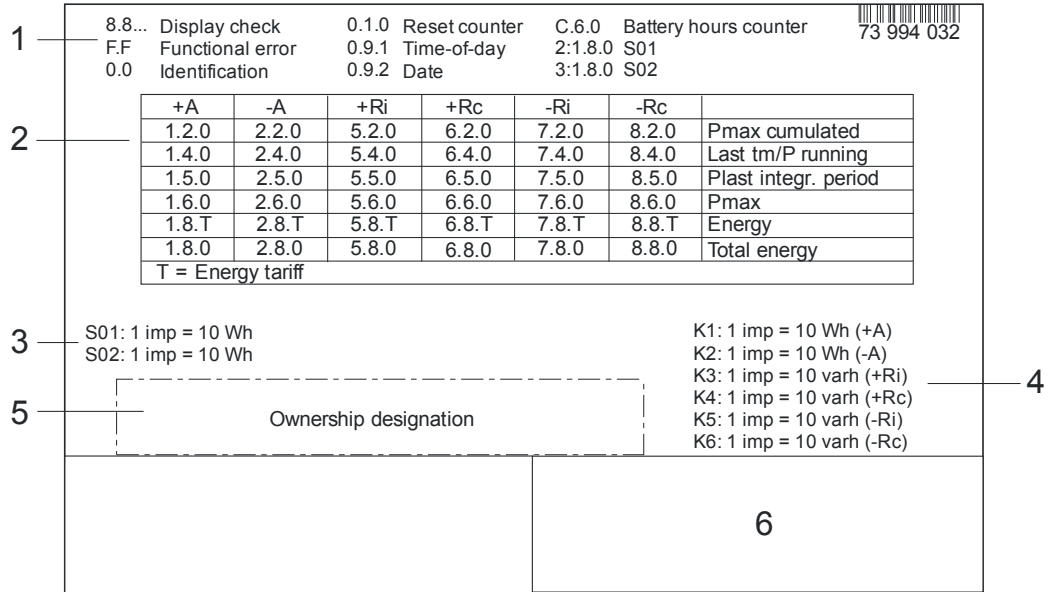

Figure 27. Tariff faceplate (example ZMD310CT)

- 1 General data appearing in the display
- 2 Measured quantities
- 3 Pulse input data
- 4 Output contact data
- 5 Ownership designation
- 6 Communication unit data (if present)

**3.3 Connections**

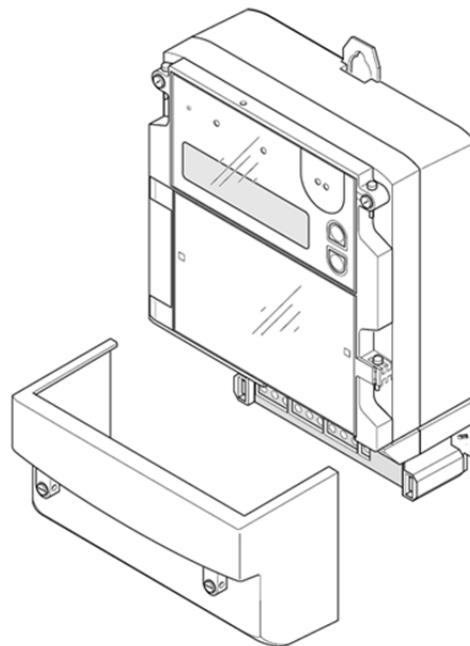

Figure 28. Meter with terminal cover removed (example ZMD300CT)

The terminal block with all meter connections is situated behind the terminal cover. Two utility seals in the fixing screws of the terminal cover prevent unauthorised access to the phase connections and therefore also prevent unrecorded energy consumption.

### Terminal layout (example ZMD300xT)

The top row of terminals (level 1) consists of spring-loaded terminals and comprises

- Extension board terminals on the left  
Depending on the version, up to 4 control inputs or 6 output contacts, 3 digital inputs and 2 relays outputs or a combination of these with maximum 6 inputs and outputs, or voltage connections for a separate supply
- Communication unit terminals on the right

The centre row of terminals (level 0) likewise consists of spring-loaded terminals and comprises

- Voltage outputs U1, U2, U3 and N, tapped from the relevant phase input
- 3 fixed control inputs with a common return line G (electrically isolated)
- 2 output contacts for transferring fixed valency pulses or control signals (electrically isolated)

The lower row of terminals comprises the phase connections with input and output of the circuit for each phase with the voltage connection in between and neutral conductor at far right.

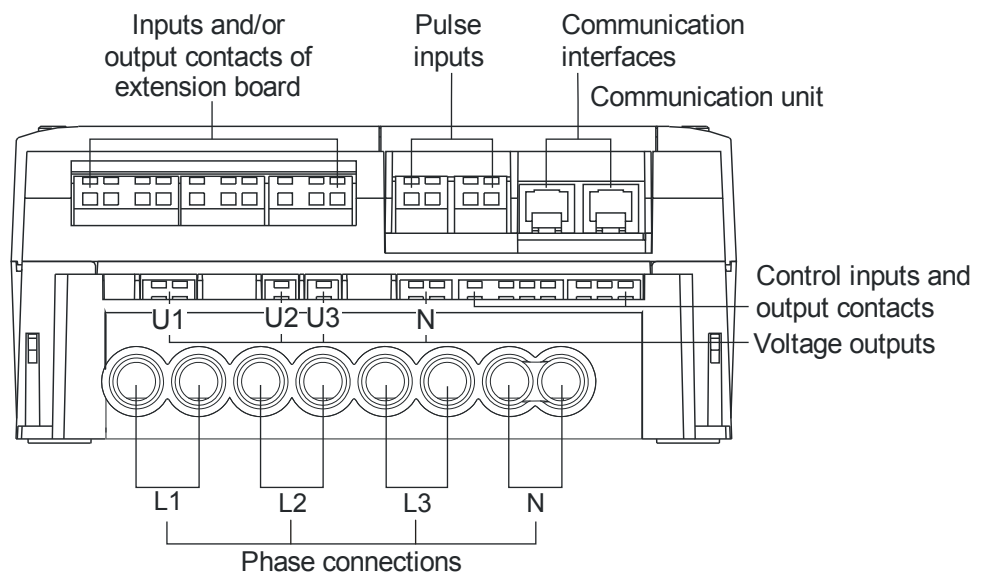

Figure 29. Terminal layout ZMD300xT

## 3.4 Connection diagrams (examples)



### Binding connection diagrams

The following connection diagrams should be considered examples. The connection diagrams provided at the rear of the front door and visible when the door is open are always binding for the installation.

**ZMD300xT  
for three-phase  
four-wire networks**

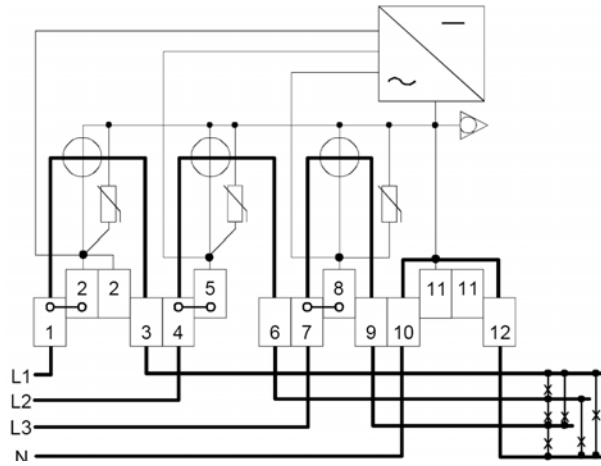
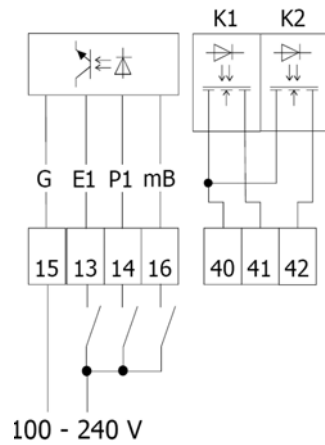

Figure 30. Connection diagram of measuring unit ZMD300xT

In case the ZMD300 is used in a 3-wire network without neutral:  
For a 3-phase, 3-wire connection, the measurement of phase-to-neutral voltage as well as the measurement of single-phase energy have no meaning, as no neutral voltage is supplied to the meter.

**Control inputs /  
output contacts**



Basic version:

3 control inputs

2 output contacts (solid-state relays)

Signal allocation and numbering of terminals for free parameterisation

100 - 240 V

Figure 31. Connection diagram fixed control inputs/output contacts

**Extension board  
4200**

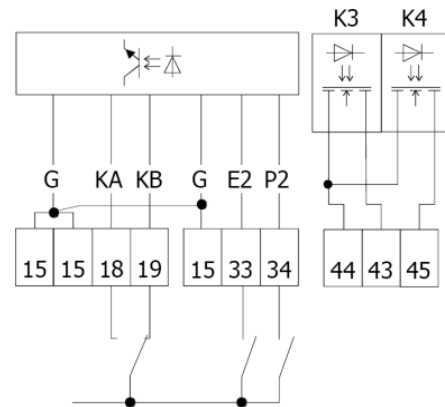

Extension board 4200:

4 control inputs

2 output contacts (solid-state relays)

Signal allocation and numbering of terminals for free parameterisation

Figure 32. Connection diagram extension board with 4 control inputs and 2 output contacts

**Extension board 2400**

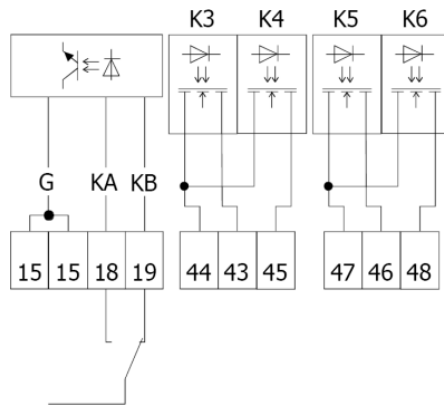

Extension board 2400:  
 2 control inputs  
 4 output contacts (solid-state relays)  
 Signal allocation and numbering of terminals for free parameterisation

Figure 33. Connection diagram extension board with 2 control inputs and 4 output contacts

**Extension board 0600**

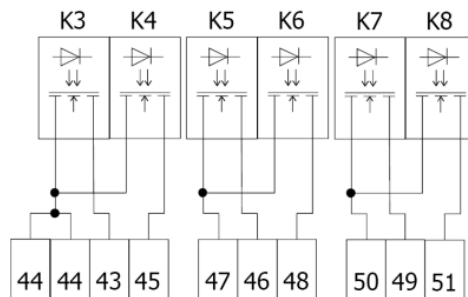

Extension board 0600:  
 no control inputs  
 6 output contacts (solid-state relays)  
 Signal allocation and numbering of terminals for free parameterisation

Figure 34. Connection diagram extension board with 6 output contacts

**Extension board 0450**

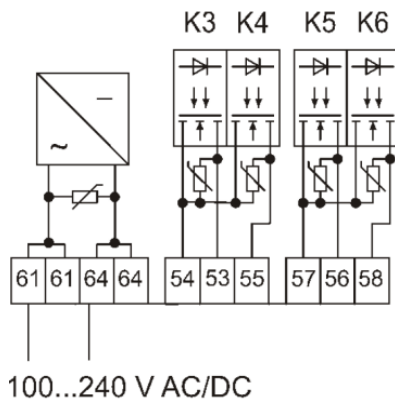

100...240 V AC/DC

Extension board 0450:  
 with auxiliary power supply  
 no control inputs  
 4 output contacts (solid-state relays)  
 Signal allocation and numbering of terminals for free parameterisation

Figure 35. Connection diagram extension board with auxiliary power supply and 4 output contacts

**Extension board 0460**

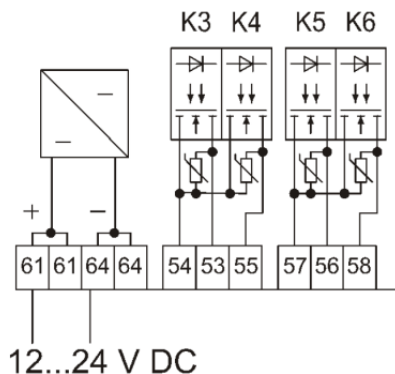

12...24 V DC

Extension board 0460:  
 with auxiliary power supply  
 no control inputs  
 4 output contacts (solid-state relays)  
 Signal allocation and numbering of terminals for free parameterisation

Figure 36. Connection diagram extension board with auxiliary power supply and 4 output contacts

**Extension board  
0470**

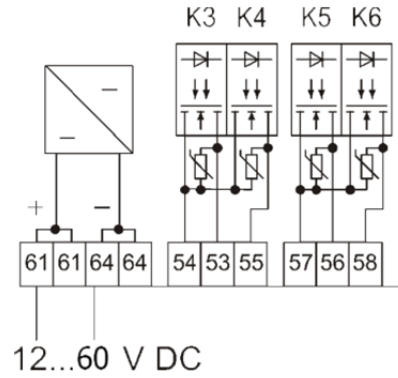

Extension board 0470:  
with auxiliary power supply  
no control inputs  
4 output contacts (solid-state relays)  
Signal allocation and numbering of terminals for free parameterisation

Figure 37. Connection diagram extension board with auxiliary power supply and 4 output contacts

**Extension board  
3260**

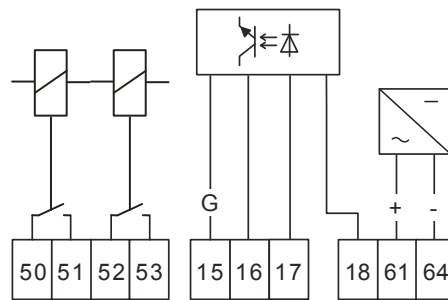

Extension board 3260:  
with auxiliary power supply  
3 control inputs  
2 relay outputs (8 A)  
Signal allocation and numbering of terminals for free parameterisation

Figure 38. Connection diagram extension board with auxiliary power supply, 3 control inputs and 2 relay outputs



**Ground terminal connection**

Please note that the Ground terminal (G) of the control inputs on the extension boards is NOT internally connected to the Ground terminal on the base. If the Ground level is the same, then an external wire must be connected between the two Ground terminals.

### 3.5 Dimensions

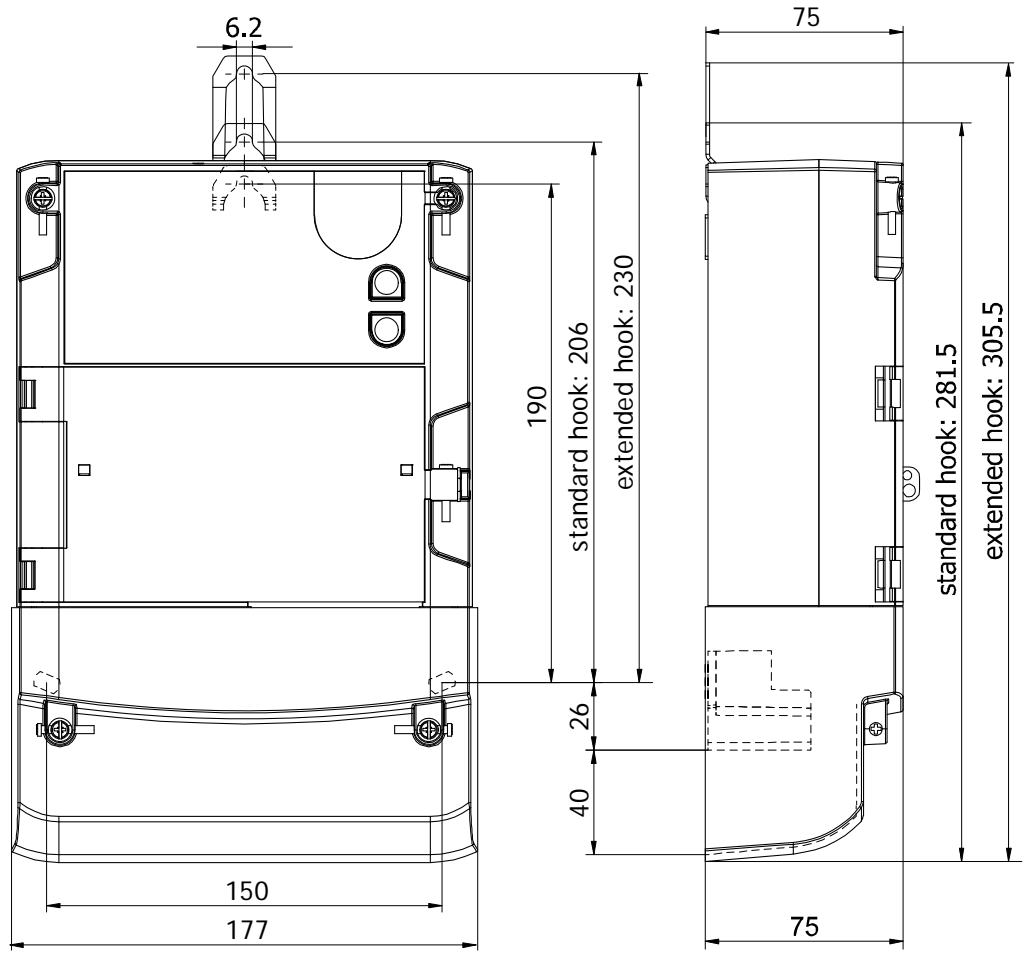

Figure 39. Meter dimensions (Standard terminal cover)

## 4 Installation and uninstallation

This section describes the installation and connection of meters for direct connection. In addition, the necessary steps for checking the connections, commissioning of the meter and the final functional check are described as well as the uninstallation.



### Dangerous voltage

Dangers can arise from live electrical installations to which the meters are connected. Touching live parts is dangerous to life. All safety information should therefore be strictly observed without fail.

### 4.1 Basic information for connecting meter

It is recommended to use the following circuits whenever possible for connecting the meter to the various voltage levels.

#### 4.1.1 Connection with 3 phases and neutral

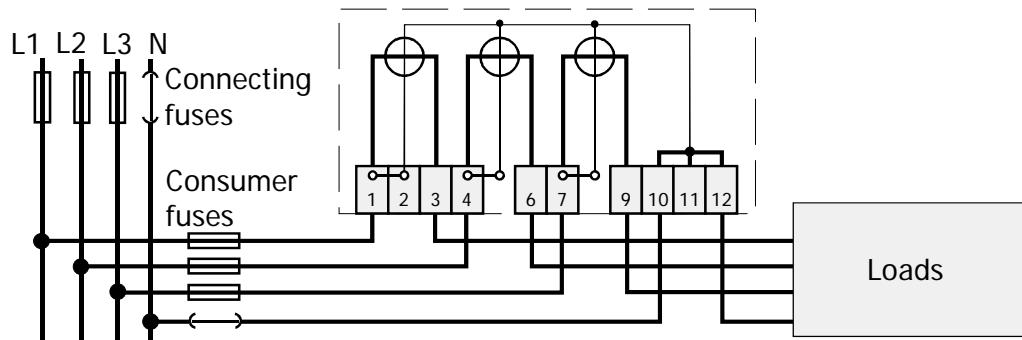

Figure 40. Connection with 3 phases and neutral

#### Neutral

The neutral is normally looped through terminals 10 and 12. Some power supply companies, however, make a simple connection between terminal 10 or 12 and the neutral. This avoids possible contact errors in the neutral conductor.

#### 4.1.2 Connection with 3 phases without neutral (Aron circuit)

A version ZFD300xT for the rarely encountered three-phase networks without neutral with 3 x 230 V is not available.

### 4.2 Mounting the meter



#### Dangerous voltage on conductors

The connecting conductors at the point of installation must be voltage-free for installation of the meter. Contact with live components is dangerous to life. The relevant supply fuses should therefore be removed and kept in a safe place until finishing work, so that they cannot be re-inserted by other persons unnoticed.

When you have identified the correct meter position for mounting the meter, it should be mounted as follows on the meter board or similar device provided for this purpose:



1. Determine the desired form of fixing (open/covered meter mounting or extended suspension hook for 230 mm suspension triangle height). If holes for a suspension triangle height of 230 mm are already present, use the **optional extended suspension hook** depicted below. This hook can be ordered with the part number 74 109 0072 0 (minimum order quantity 50) from:

Landis+Gyr AG  
Service & Repair  
Theilerstrasse 1  
CH-6301 Zug  
Switzerland

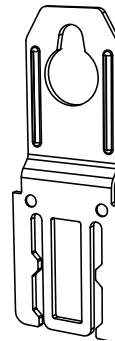

Figure 41. Extended suspension hook for installations with 230 mm suspension triangle height

2. Either set the meter suspension hook in the relevant position as shown below or replace the suspension hook with the extended hook by lifting the latch slightly and pulling out the shorter hook. Insert the extended hook into the grooves in the same way the shorter hook was inserted (bent towards rear) and push it down until it clicks into place.

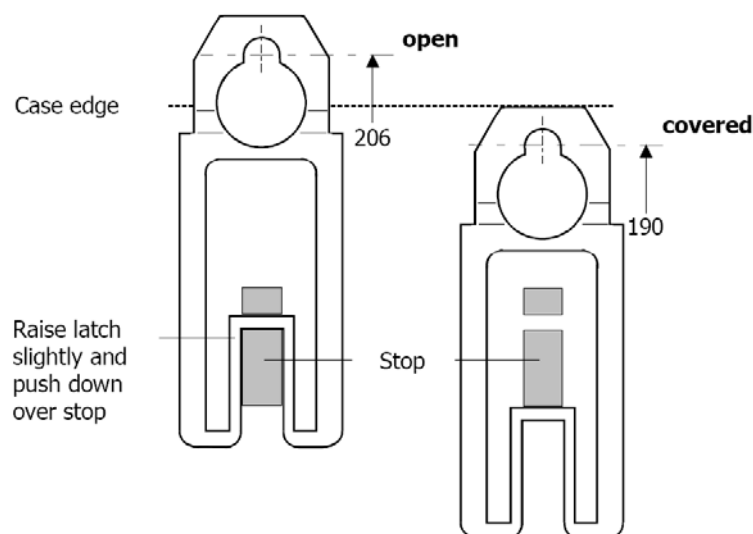

Figure 42. Positioning of meter suspension eyelet

3. Check with a phase tester or universal measuring instrument whether the connecting wires are live. If so, remove the corresponding supply fuses and keep them in a safe place until installation is completed, so that they cannot be replaced by anyone unnoticed. Open the voltage connections at the test terminal block with an insulated screwdriver and check whether the short-circuit jumpers of the circuit are closed.
4. In case there are no holes provided, e.g. as in the case with the 230 mm suspension triangle: Mark the three fixing points (suspension triangle as in following illustration) on the mounting surface provided:
  - horizontal base of suspension triangle = 150 mm
  - height of suspension triangle for open mounting = 206 mm
  - height of suspension triangle for covered mounting = 190 mm

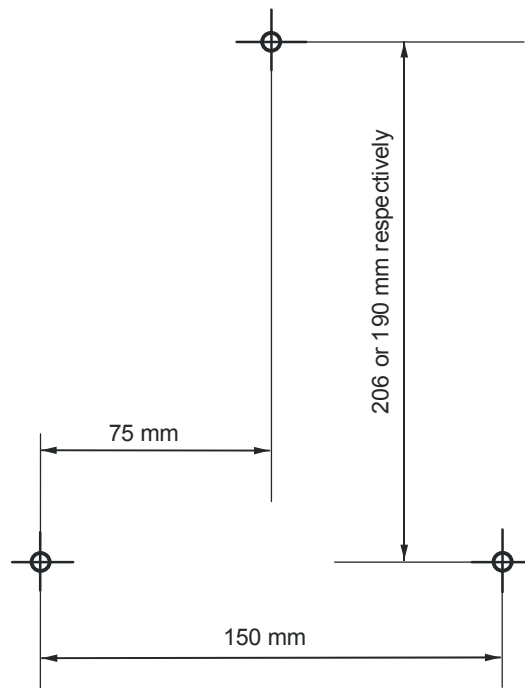

Figure 43. Drilling plan

5. Drill the three holes for the fixing screws.
6. Unscrew the meter terminal cover.
7. Fit the meter with the three fixing screws on the mounting surface provided.

### 4.3 Connecting meter



#### **Dangerous voltage on conductors**

The connecting conductors at the point of installation must be voltage-free for installation of the meter. Contact with live components is dangerous to life. The relevant supply fuses should therefore be removed and kept in a safe place until finishing work, so that they cannot be re-inserted by other persons unnoticed.



#### **Connecting conductor cross-section**

ZMD310CT meters with a maximum current of 100 or 120 A require connecting conductors of 35 mm<sup>2</sup> cross-section. Owing to the terminal opening of 9.5 mm, only cable is possible.

The electrical connections to the meter should be made as follows according to the connection diagram:

1. Check with a phase tester or universal measuring instrument whether the connecting wires are live. If so, remove the corresponding supply fuses and keep them in a safe place until installation is completed, so that they cannot be replaced by anyone unnoticed.

#### **Connecting the phase connection lines**

1. Shorten the phase connecting wires to the required length and then strip them.

2. Insert the phase connecting wires in the relevant terminals (the terminals are numbered as shown in the connection diagram) and tighten the terminal screws firmly (torque 3 to 5 Nm).

With small conductor cross-sections (e.g. 4 mm<sup>2</sup>) the connecting line must be placed in the indentation (stamping) of the current loops, so that it cannot shift sideways when tightening the terminal screws. Ensure that the connecting line remains in the indentation when tightening.

Indentation (stamping) for smaller connection lines

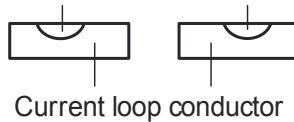

Figure 44. Cross-section through current loop conductor

If smaller connection lines are used, it's possible to adapt the cable section with terminal holes using "assembling aids" or "centering parts" in order to have a safe connection:

- P000225650 (x100 pcs) – 8.5 mm
- P000172980 (x100 pcs) – 9.5 mm

Please contact your sales representative for ordering.

It is recommended to identify the beginning and end of the relevant conductors with a suitable test unit (e.g. buzzer) to ensure that the right consumer is connected to the meter output.

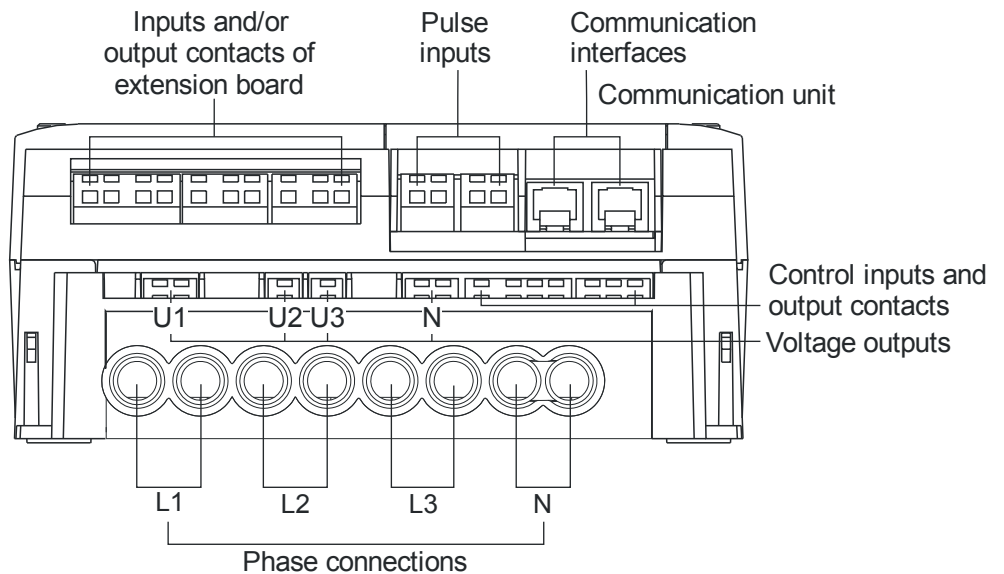

Figure 45. Meter connections (example ZMD300xT)

**Power losses at the terminals**



Insufficiently tightened screws at the phase connections can lead to increased power losses at the terminals and therefore to undesirable heating. A contact resistance of 1 mΩ causes a power loss of 10 W at 100 A!

## Connecting the signal inputs and outputs

### Maximum current at auxiliary terminals

The circuits connected to the auxiliary terminals must be built in such a way that the maximum current is never exceeded, as this might damage the meter.



**Maximum current of the voltage outputs: 1 A.**

**Maximum current of the output contacts: 100 mA.**

Use fuses or protective relays between external and internal circuits to avoid defects and a possible exchange of the meter.

1. Shorten the connecting wires of the signal inputs and outputs to the required length and strip them for approx. 4 mm (wires and strands up to 2.5 mm<sup>2</sup> can be connected).



### Use ferrules with stranded wires

If stranded wire is used, provide it with ferrules for connection.

2. Connect the connecting wires of the signal inputs and outputs as follows to the screwless spring-loaded terminals (the terminals are numbered as shown on the connection diagram):
  - Insert a size 1 screwdriver in the upper opening and insert it turning slightly upwards (figure 46 A).
  - Now place the stripped connecting wire in the lower opening and hold it there securely (figure 46 B).
  - Withdraw the screwdriver. The connecting wire is then firmly fixed (figure 46 C).

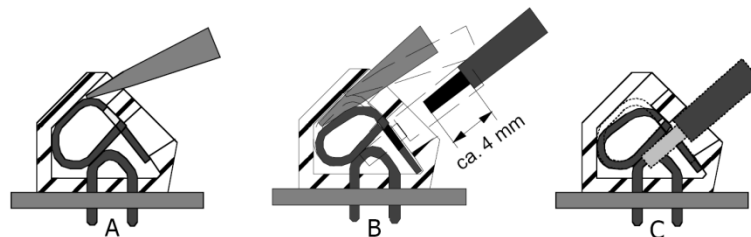

Figure 46. Connection in screwless spring-loaded terminals



### Bare end of connecting wire must not be too long

The insulation of the connecting line must extend as far as the terminal indentation, i.e. there must be no further bare part of the connecting line visible above the terminal edge (as shown in figure 46 C). Touching live parts is dangerous to life. The stripped part of the connecting wire should be shortened if necessary.



### Only one wire or ferrule per terminal

Only one wire or ferrule with strand(s) may be connected in screwless spring-loaded terminals. The terminal could otherwise be damaged or the contact not properly made.

If a connecting wire must be disconnected again for any reason, this is performed in the reverse sequence:

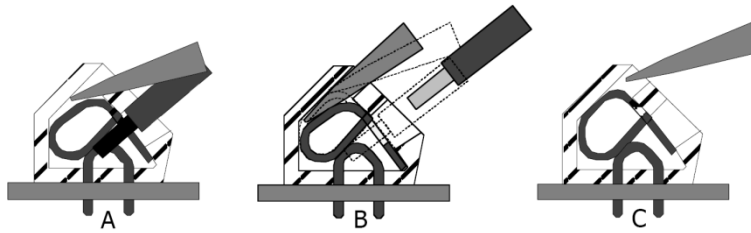

Figure 47. Releasing connection from spring-loaded terminal



**Damage to terminals**

Never withdraw connecting wires with the terminal closed, since this could damage the terminal.

**4.3.1 Connecting the RS485 interface**

If you connect the RS485 interface you must not strip back the shielded cables, e.g. to connect the individual wires to an external terminal block (see figure below), as this considerably increases the likelihood of interference.

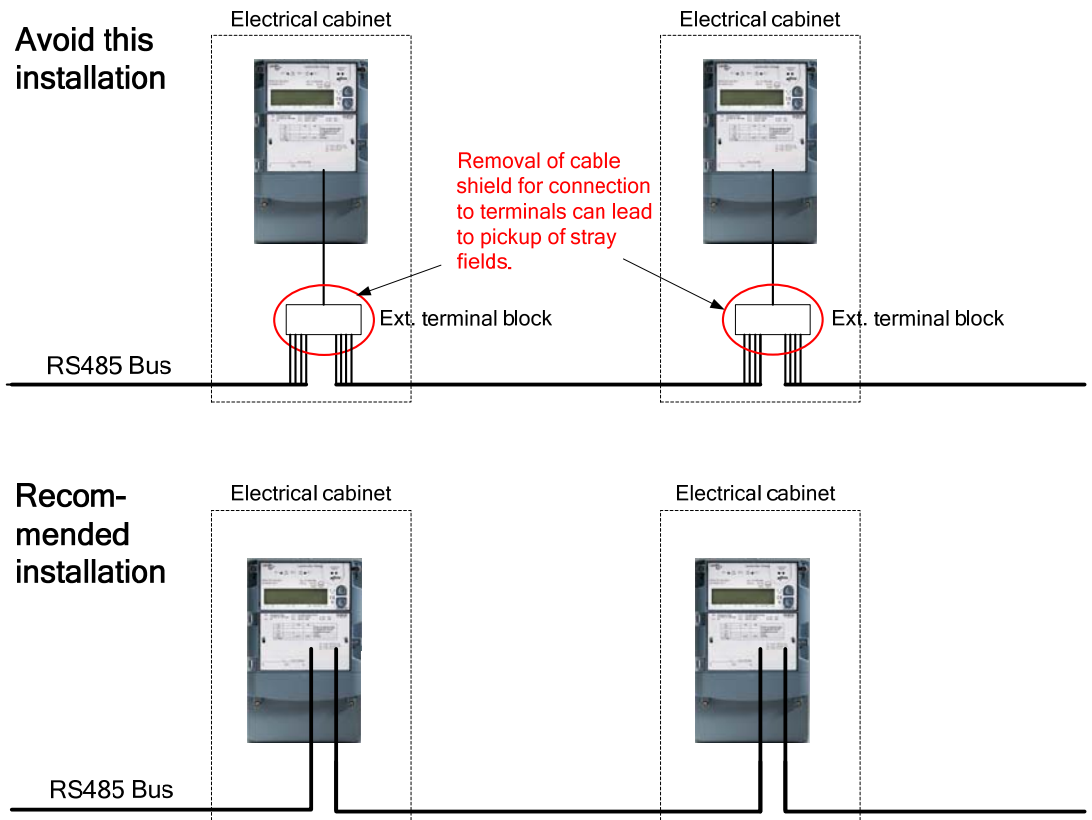

Figure 48. How to connect RS485 correctly

It is also possible to use RS485 distributors instead of connecting the RS485 cables directly to the meter.

## 4.4 Check of connections



### Effects of connection errors

Only a properly connected meter measures correctly!  
Every connection error results in a financial loss for the power company!

Before putting into operation, check again whether all meter connections are connected correctly according to the connection diagram.

## 4.5 Commissioning, functional check and sealing



### Dangerous voltage on conductors

The supply fuses must be re-inserted before commissioning and functional check of the meter. If the terminal cover is not screwed tight, there is a danger of contact with the connection terminals. Contact with live components is dangerous to life. The relevant supply fuses should therefore be removed before making any modifications to the installation and these kept in a safe place until completing the work to prevent anyone re-inserting them unnoticed.



### Prerequisites for commissioning and functional check

If no mains voltage is present, commissioning and functional check must be performed at a later date.

The installed meter should be put into service and checked as follows:

1. Insert the supply fuses removed for installation. The meter is switched on.
2. Check whether the operating display is correct (no error message).
3. Check on the display whether all three phases L1, L2 and L3 are indicated and show the right phase sequence.
  - If one phase is not present or less than 20 V, then the relevant symbol is absent.
  - With the normal phase sequence L1-L2-L3 the symbols are displayed continuously.
  - If, however, the meter is connected with reversed phase sequence (e.g. L2-L1-L3) the symbols flash. The direction of field rotation (clockwise or anticlockwise) is determined by the parameterisation. This has no influence on the measuring behaviour of the meter.

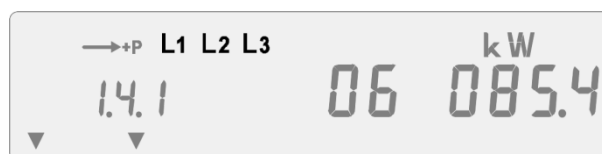

Figure 49. Phase sequence indication

4. Remove all supply fuses.

5. Insert the supply fuse of phase 1 and check the display of the energy direction: +P to right. If the energy direction arrow P points to the left, the input and output of phase 1 are interchanged. If the meter displays no energy direction, the calibration link is open, the supply fuse is defective or the neutral is not connected.
6. Remove the supply fuse of phase 1 again.
7. Repeat the same test for the other phases as in points 5 and 6.
8. You can now check further values such as phase voltages. This is preferably done with MAP110 or, if parameterised, via the service list, which you can reach via the service menu.
9. Check the tariff displays and switch the control voltages to the tariff inputs on and off. The arrow symbols of the tariff display must change.
10. If the meter is connected to a meter readout system via the electrical interface, check the data transmission.
11. If a GSM modem is connected to the meter, the SMS transmission function should be checked by sending a test SMS message according to the instructions found in the respective application note or user manual, e.g. to your own mobile telephone.
12. Mount the terminal cover if the meter is operating correctly. Otherwise first locate and eliminate the error.
13. Seal the terminal cover with two utility seals.
14. Set the current date and time with the relevant formatted command (see section 5.8 "Input of formatted commands") or in the set mode (see section 5.9 "Set time and date, ID numbers, battery time").
15. Close the front door.
16. Re-seal the front door.

## 4.6 Installation of terminal cover detection

1. Ensure that control input 1 has been parameterised for this function.
2. Connect cables 1 and 2 to terminal according to the figure below.

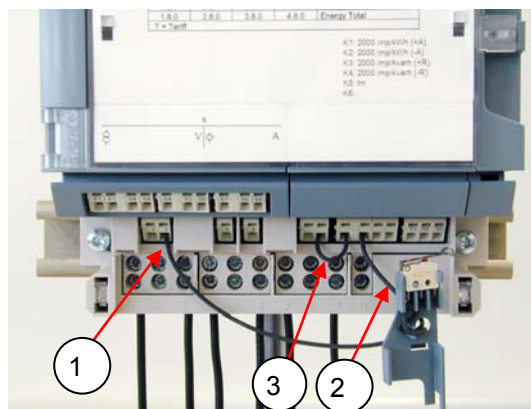

Figure 50. Connection of cables of cover detection unit

3. Fix terminal cover detection unit to meter. See figure below.



Figure 51. Fixing of cover detection unit to meter

4. Connect cable 3 as shown above.

## 4.7 Uninstallation



### Dangerous voltage on conductors

The connecting wires at the place of installation must not be live when removing the meter. Touching of live parts is dangerous to life. Remove the corresponding supply fuses and keep these in a safe place until work is completed, so that they cannot be replaced by anyone unnoticed.

The meter should be removed as follows:

1. Remove the two utility seals at the screws of the terminal cover.
2. Release the two screws of the terminal cover and remove it.
3. Check that the connecting wires are not live using a phase tester or universal measuring instrument. If they are live, remove the corresponding supply fuses and keep these in a safe place until work is completed, so that they cannot be replaced by anyone unnoticed.
4. Remove the connecting wires of the signal inputs and outputs from the screwless spring-loaded terminals as follows:
  - Place a size 1 screwdriver in the upper opening and insert it turning slightly upwards (figure 52 A).
  - Then draw the wire from the lower opening (figure 52 B).
  - Withdraw the screwdriver (figure 52 C).

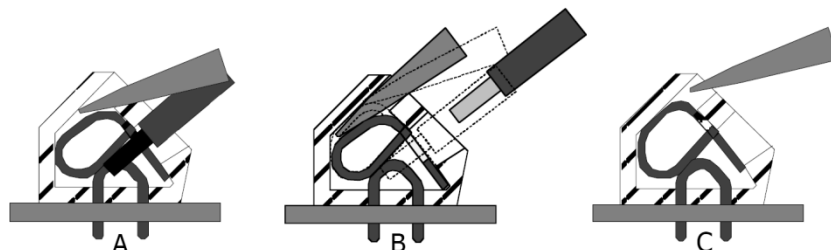

Figure 52. Removing connections in screwless spring-loaded terminals



### Damage to terminals

Never withdraw connecting wires from closed terminals. The terminals could be damaged.



5. Release the terminal screws 1, 3, 4, 6, 7, 9, 10 and 12 of the phase connecting wires with a suitable screwdriver and withdraw the phase connecting wires from the terminals.
6. Fit a substitute meter as described in section 4.3 "Connecting meter" and the following sections.

## 5 Operation

This section describes the location and function of all operating elements and displays of the E650 ZMD300xT meters as well as operating sequences.



### Illustrations

The illustrations of the faceplate and display in this section always show the ZMD300CT combi-meter (with additional optical test output for reactive energy, together with direction of reactive power and quadrant display).

### 5.1 Operation with auxiliary power supply

Meters equipped with an auxiliary power supply which is supplied with electricity (see section 3.4 "Connection diagrams (examples)") are completely functional even in case of a power cut. Despite missing voltage at the terminals they can be read out via display, remote readout, etc. and parameterised, if desired.

Connect the auxiliary power supply as follows:

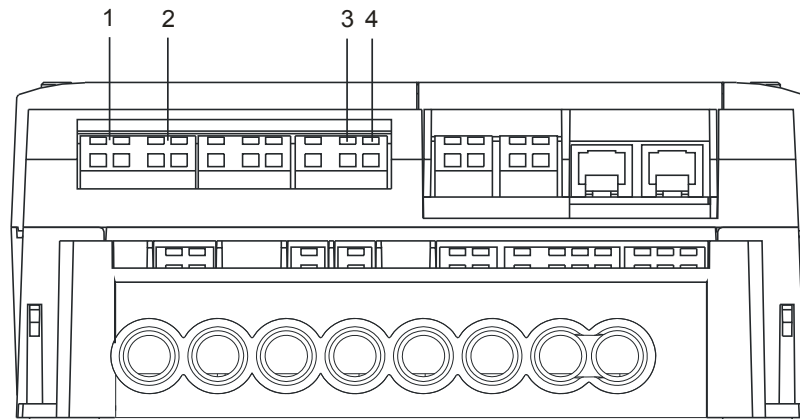

Figure 53. Auxiliary power supply connections  
 Type 045x: 1 and 2: 100–240 V AC/DC  
 Type 046x: 1: + (12–24 V DC)  
 Type 046x: 2: – (12–24 V DC)  
 Type 326x: 3: + (12–24 V DC)  
 Type 326x: 4: – (12–24 V DC)

### 5.2 Control elements

E650 meters have the two display buttons "down" and "up" and a reset button as conventional operating elements. The display can also be controlled with the aid of a light source via the optical interface.

#### 5.2.1 Display buttons

The two display buttons "down" and "up" are placed on the main faceplate (top) on the right of the liquid crystal display.

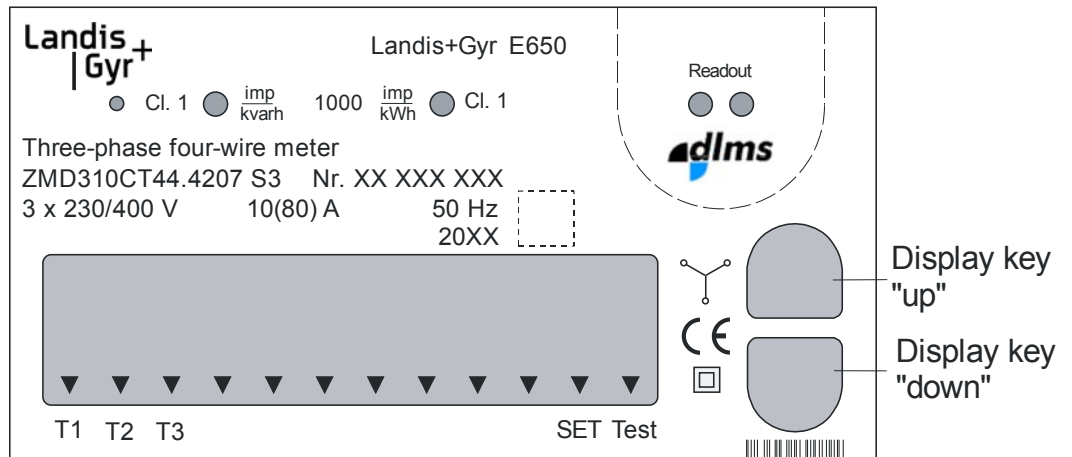

Figure 54. Display buttons

By pressing the lower display button "down", the display changes to the next value in the list. By pressing the upper display button "up", the display changes to the previous value (also see section 5.4.2 "Display menu").

### 5.2.2 Control of display via optical interface

All E650 meters have an "optical button" in addition to the "up" and "down" display buttons. The optical interface serves to receive a light signal, e.g. generated by a torch (works only with warm light, i.e. LED torches cannot be used for this). The light signal acts like the "down" display button and controls the display in one direction from one value to the next. This type of display control only functions when voltage is supplied to the meter.

The reader can also control the display at a distance from the meter depending on the light intensity from the source, e.g. through a protective glass in front of the meter.

### 5.2.3 Reset button

The reset button is situated to the right of the battery compartment behind the front door. To permit operation of the reset button the front door must be opened and therefore the utility seal be removed.

The reset button can be used to perform a manual reset. If the display check is displayed (after operation of a display button), however, pressing the reset button produces the service menu (also see section 5.4.3 "Service menu").

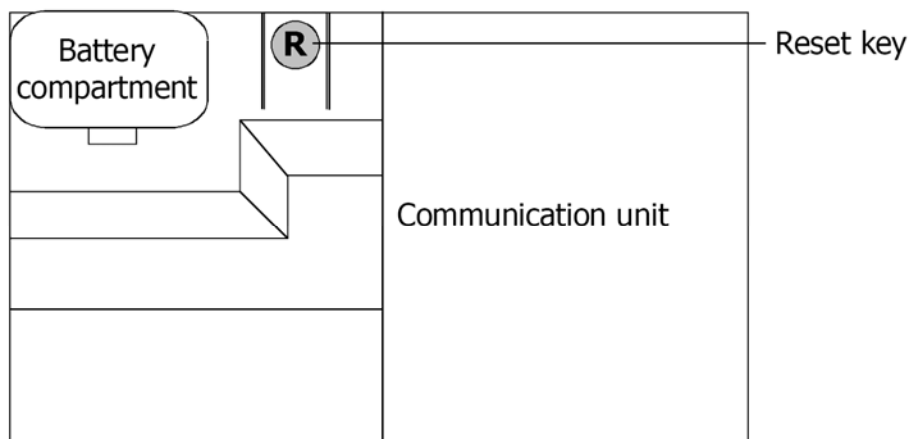

Figure 55. Reset button behind front door

## 5.3 Display

### 5.3.1 Introduction

E650 meters are provided with a liquid crystal display (LCD).

The display can be provided with background lighting for easier reading (optional). This is switched on by pressing one of the display buttons and is extinguished automatically after a short time if no further button is pressed.

### 5.3.2 Basic layout

The basic layout shows all the indication possibilities of the display.

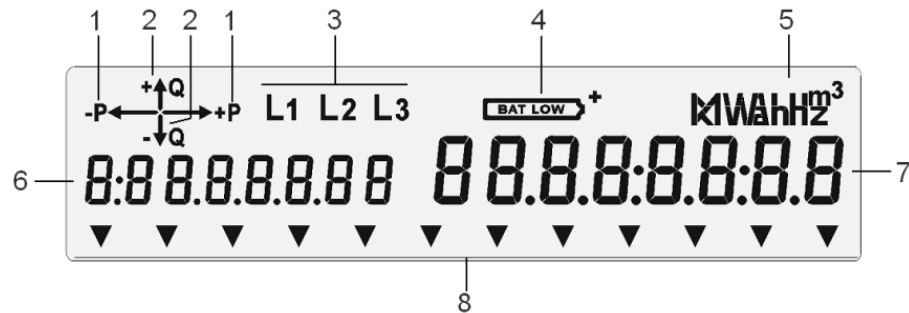

Figure 56. Basic layout of the liquid crystal display (LCD)

- 1 Active power direction (+P: import, -P: export)
- 2 Reactive power direction (not used with ZMD300AT)
- 3 Phase voltages (flash if rotating field reversed)
- 4 Battery status (charge voltage)
- 5 Units field
- 6 Index field (8 digits)
- 7 Value field (8 digits)
- 8 12 arrow symbols for status information (e.g. tariffs)

#### Active power direction

Shows always the sum of the three phases:

- +P** positive active energy direction (imported from power company)
- P ←** negative active energy direction (exported to power company)
- P ← → +P** negative active energy direction of individual phases (second arrow flashes).

#### Reactive power direction

Indicates for combi-meters ZMD300CT always the sum of the three phases (not used for active energy meters ZMD300AT).

- +↑Q** positive reactive energy direction
- ↓Q** negative reactive energy direction

#### Quadrant display

Indicates for combi-meters ZMD300CT in which quadrants the present measurement is made (not used for active energy meters ZMD300AT):

- ↑Q → +P** 1<sup>st</sup> quadrant
- P ← +↑Q** 2<sup>nd</sup> quadrant
- P ← -↓Q** 3<sup>rd</sup> quadrant
- ↓Q → +P** 4<sup>th</sup> quadrant

<b>Phase voltages</b>	<b>L1 L2 L3</b>	Indication of presence of phase voltages. If the rotating field corresponds to the parameterised, symbols L1, L2 and L3 are continuously lit. Otherwise they flash every second.
<b>Battery condition</b>		The symbol appears if the charge voltage of the battery fitted is too low (provided the meter is parameterised as "fitted with battery").
<b>Units field</b>	<b>KVAhHz<sup>m3</sup></b>	The following units are shown: W, var, VA, k..., M..., ...h, V, A, h, Hz, m <sup>3</sup> (var and VA only for combi-meters)
<b>Index field</b>	<b>8:88888888</b>	Up to 8-digit indices are displayed, which define the value in the value field.
<b>Value field</b>	<b>88888888</b>	Up to 8-digit values are displayed.
<b>Arrow symbols</b>	<b>▼ ▼ ▼ ▼</b>	An arrow symbol is an additional status indication for tariff rates, reset block, test mode, etc. The arrow points to a status description on the faceplate.

### 5.3.3 Index system

The information concerning which data are shown in the display is made with an index system and is supported by the unit over the value field.

The 8-digit index field permits all currently known index systems such as DIN, LG, VEOe, OBIS, etc.

The **B:C.D.E.F** structure applies to OBIS (Object Identification System):

- B** Defines the channel number, i.e. the number of the input of a metering device having several inputs for the measurement of energy of the same or different types (e.g. in data concentrators, registration units). This enables data from different sources to be identified.
- C** Defines the abstract or physical data items related to the information source concerned, e.g. active power, reactive power, apparent power,  $\cos\phi$ , current or voltage.
- D** Defines types, or the result of the processing of physical quantities according to various specific algorithms. The algorithms can deliver energy and demand quantities as well as other physical quantities.
- E** Defines the further processing of measurement results to tariff registers, according to the tariff rates in use. For abstract data or for measurement results for which tariffs are not relevant, this value group can be used for further classification.
- F** Defines the storage of data according to different billing periods. Where this is not relevant, this value group can be used for further classification.

To simplify reading of the index field, individual parts of the OBIS code can be omitted. The abstract or physical data C and type of data D must be shown.

For further details about OBIS code see Appendix 1.

#### Examples

**1.8.0:** 1 = Active energy import (all phases); 8 = Status; 0 = Total

**0.9.1:** Local time

Reference is made for examples to the following display list and the readout log (see section 5.7 "Data readout")

## 5.4 Types of display

The ZMD300xT has the following three types of display:

- Operating display** The values specified by the parameterisation are shown as a rolling display in the operating display. The display is always in operating mode when the display buttons are not operated. The meter returns automatically from the display list to the operating display after a defined time. This display can consist of one or more values.
- Display menu** By pressing the display button, the display check is activated, and from there the user reaches the display menu by pressing the display button again. From the display menu, values of the display list, the load profile(s), the event log, etc. can be accessed. The values of the display list and also the sequence can be parameterised. The display buttons permit scrolling up and down in the list.
- Service menu** The user reaches the service menu by pressing the reset button starting from the display check. From the service menu, values of the service list, the set mode, etc. can be accessed. The service list, for example, is an extended display list with additional values.

### 5.4.1 Operating display

The values always displayed are considered the operating display. This can be parameterised as a fixed display (only one value present, e.g. the present tariff rate) or as a rolling display (several values alternate at a fixed rate, e.g. every 15 seconds).



running average demand value with status of integrating period

Figure 57. Example of a fixed display

### Error message

The meter can generate an error message on the basis of self-tests. According to parameterisation, this can be permanently included in the operating display. In the event of a serious error (fatal or critical error), it replaces the normal operating display. After a fatal error, the meter no longer operates and must be replaced. In case of a critical error, the error message can be acknowledged with the display button.



Figure 58. Example of an error message (insufficient battery voltage)

In case of an error message the procedure described in section 6.2 "Error messages" should be followed.



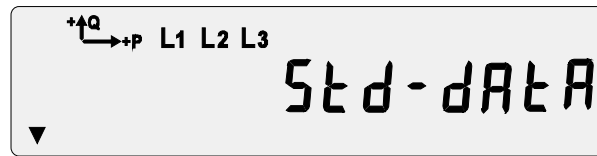

The menu item only appears when several menu items exist. Otherwise direct entry is made to the display list.

The next menu item appears for every further **brief** operation of the "down" display button, e.g. "Data profile", "Event log", etc. The first menu item appears again after the last item.

The preceding menu item is displayed again by **briefly** pressing the "up" display button.

Both display buttons ("down" and "up") must be pressed **simultaneously** to return to the operating display from any display menu.

**Value display**

The first value of the list associated with the present menu is displayed by pressing the display button "down" or "up" for **longer** (at least 2 seconds), and is normally the error message:



The next list value appears for every further brief operation of the "down" display button. **Brief** operation of the "up" button again displays the preceding value. The sequence of values in the list is determined by the parameterisation.

A rapid run is started by holding down the display button "down" or "up" for **longer** (at least 2 seconds). The main values of the list are then displayed while the button remains pressed, but no stored values.

Examples of values in a display list:

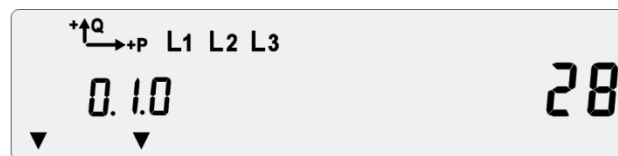

Reset counter



Date of resetting  
stored value 03 (March)



Cumulated maximum demand  
active power rate 1



Active energy present status  
rate 1



	Reactive energy present status rate 1
	Battery hours counter
	Status of signals at control terminals
	Number of total voltage failures

To return to the menu level from the list at the end of the display list press the display button "down" or "up" for **longer** (at least 2 seconds).

**Load profile 1**

The load profile 1 menu item for selection in the display menu (denoted P.01) is shown as follows:

The first value of the load profile 1 is displayed by pressing the display button "down" or "up" for **longer** (at least 2 seconds).

**Load profile 2**

The load profile 2 menu item for selection in the display menu (denoted P.02) is shown as follows:

The first value of the load profile 2 is displayed by pressing the display button "down" or "up" for **longer** (at least 2 seconds).

**Event log**

The event log menu item for selection in the display menu (denoted P.98) is shown as follows:

The first entry in the event log is displayed by pressing the display button "down" or "up" for **longer** (at least 2 seconds).

### 5.4.3 Service menu

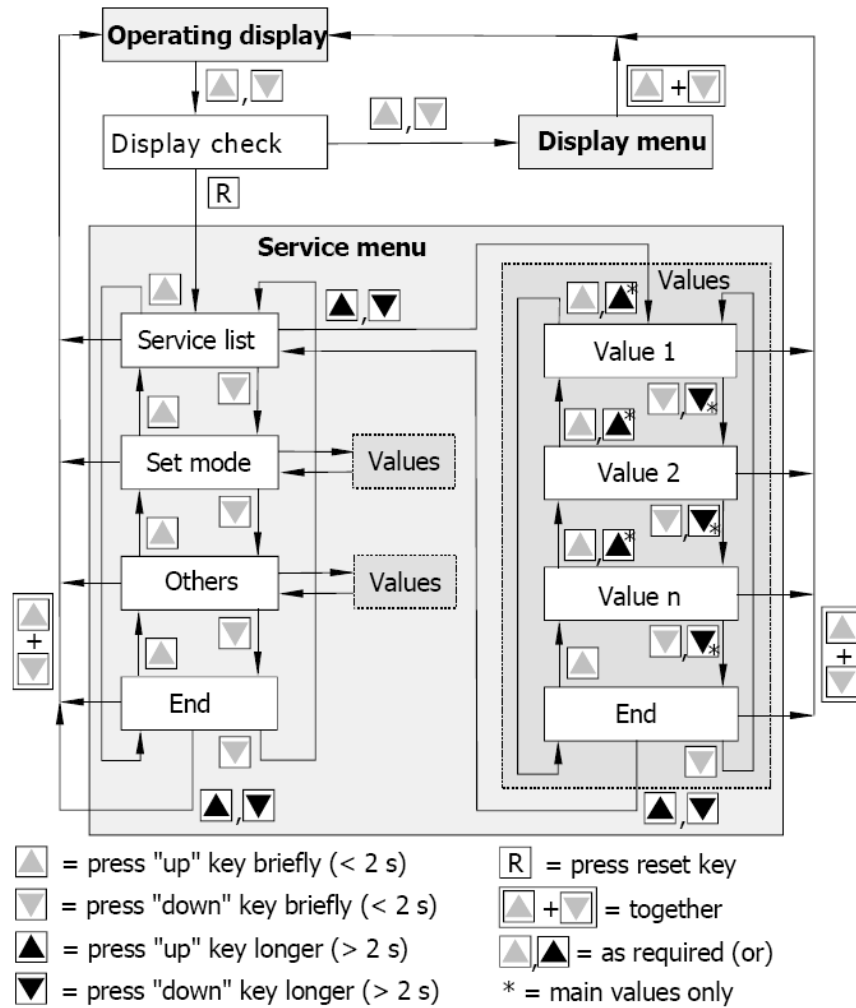
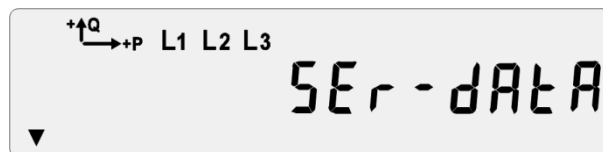

Figure 60. Service menu overview

#### Service menu

Pressing the reset button during the display check changes the display to the service menu or directly to the service list. The first menu item appears, e.g. the service list:



The menu item only appears if there are several items present. Otherwise pressing the reset button directly leads to the values of the service list.

The next menu item appears for every further **brief** operation of the "down" display button, e.g. "Set mode", "Test mode on/off", etc. The first item appears again following the last menu item "End".

The preceding menu item appears again by pressing the "up" button **briefly**.

Both display buttons ("down" and "up") must be pressed **simultaneously** to return to the operating display from the service menu.

#### Value display

The first value of the list associated with the present menu is displayed by pressing the display button "down" or "up" for **longer** (at least 2 seconds).

The next list value appears for every further brief operation of the "down" display button. **Brief** operation of the "up" button again displays the

preceding value. The sequence of values in the list is determined by the parameterisation.

A rapid run is started by holding down the display button "down" or "up" for **longer** (at least 2 seconds). The main values of the list are then displayed while the button remains pressed, but no stored values.

To return to the menu level from the list at the end of the display list press the display button "down" or "up" for **longer** (at least 2 seconds).

Both display buttons ("down" and "up") must be pressed **simultaneously** to return to the operating display from the list.

**Set mode**

Values can be changed in the set mode with the aid of the reset button and display buttons (for setting time and date, identification numbers, battery hours counter, etc.). The procedure is described in section 5.9 "Input of formatted commands".

**5.5 Alert LED**

The red alert LED (optional) on the main faceplate indicates that certain event(s) have occurred. Which event(s) trigger the alert LED can be set by parameterisation.

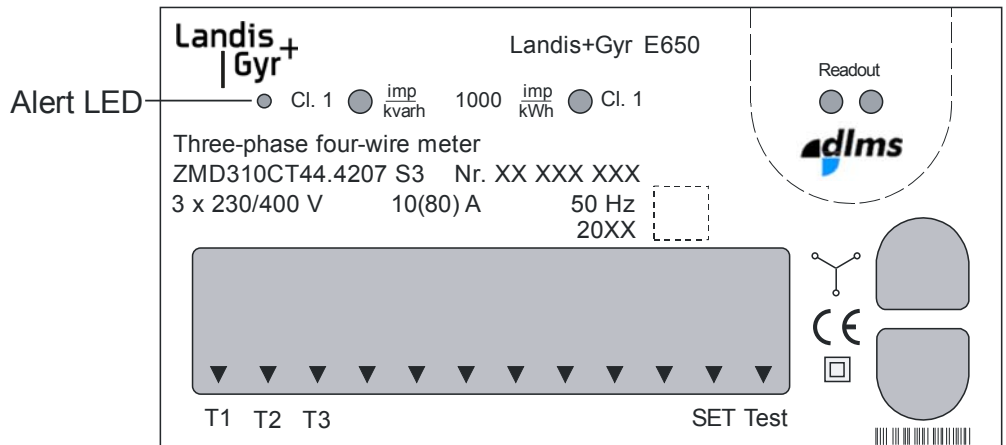

Figure 61. Alert LED

**5.6 Optical test output**

The optical test outputs – one for active energy in all meters and a second for reactive energy in combi-meters – are fitted in the main faceplate above the liquid crystal display.

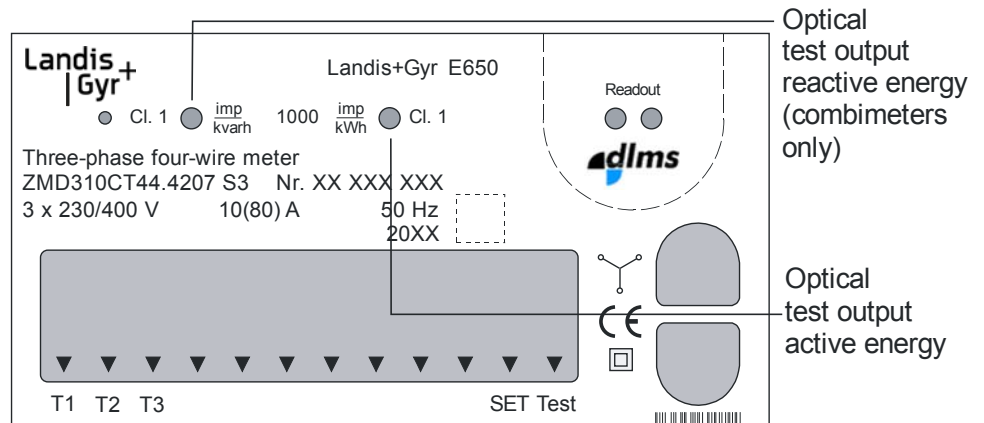

Figure 62. Optical test outputs

The optical test outputs are used for testing the meter (also see section 7.1 "Meter testing"). They transmit visible red pulses corresponding to the current measured values (active and reactive energy).

## 5.7 Data readout

The energy supply company can record the data stored locally in the meter at any time in two ways:

- Reading the liquid crystal display of the meter. The displayed data is defined by parameterisation.
- Automatic data readout via the optical interface with a readout device (e.g. laptop).



### Readout data

For readout to IEC 62056-21, all data determined by the parameterisation are read out in the specified sequence.

For readout according to DLMS (Device Language Message Specification), the data requested by the readout unit are read out.

If the meter is fitted with the appropriate communication unit (see associated separate operating instruction), remote readout of the meter data is also possible.

### Procedure for data readout via optical interface

1. Start the readout device (according to the details in the associated operating instructions).
2. Connect the cable of the reading head to the readout device.
3. Place the reading head in the "Readout" indentation on the plastic viewing window of the meter. The reading head cable must point towards the terminal cover (when mounted vertically downwards). The reading head is held magnetically.
4. Start the data readout on the readout device (according to the details in the associated operating instructions).
5. Remove the reading head from the meter again after completing the readout.

### 5.7.1 Readout to IEC 62056-21

The data read out according to IEC 62056-21 are recorded in the form of the example shown below. The quantity and sequence of values in the log is determined by parameterisation.

#### Log example

```
/LGZ4\2ZMD3104100
F.F (00000000)
0.0.1 (417242)
0.1.0 (28)
0.1.2.04 (98-05-01 00:00)
```

#### Significance

```
Designation of meter
(reply on transmit request)
Error message
1st identification number
Number of resets
Time of last reset
```

1.2.1 (26068.7*kW)	P <sub>max</sub> cumulated	Rate 1
1.2.2 (15534.8*kW)	P <sub>max</sub> cumulated	Rate 2
1.6.1 (192.4*kW)(00-05-06 10:45)	P <sub>max</sub> present	Rate 1
1.6.1*04 (202.4)(00-04-22 09:30)	with April stored value <sup>1)</sup>	Rate 1
1.6.2 (086.7*kW)(00-05-04 22:30)	P <sub>max</sub> present	Rate 2
1.6.2*04 (100.9)(00-04-14 23:00)	with April stored value <sup>1)</sup>	Rate 2
1.8.1 (0244948*kWh)	Active energy (import)	Rate 1
1.8.1*04 (0234520)	with April stored value <sup>1)</sup>	Rate 1
1.8.2 (0082520*kWh)	Active energy (import)	Rate 2
1.8.2*04 (0078197)	with April stored value <sup>1)</sup>	Rate 2
5.8.1 (0106103*kvarh)	Reactive energy (inductive)	Rate 1
5.8.1*04 (0100734)	with April stored value <sup>1)</sup>	Rate 1
5.8.2 (0039591*kvarh)	Reactive energy (inductive)	Rate 2
5.8.2*04 (0036152)	with April stored value <sup>1)</sup>	Rate 2
1.8.0 (0327468*kWh)	Total active energy	
5.8.0 (0145694*kvarh)	Total reactive energy (inductive)	
8.8.0 (0001452*kvarh)	Total reactive energy (capacitive)	
0.9.1 (14:18:06)	Time-of-day of readout	
0.9.2 (00-05-20)	Date of readout	
C.7.0 (00087)	No. of voltage failures of all phases	
C.72.0 (00157)	Number of under-voltages	
C.73.0 (00000)	Number of over-voltages	
C.74.0 (00306)	Number of over-loads (over-current)	
C.3.0 (500)	Active pulse constant	
C.3.1 (500)	Reactive pulse constant	
C.2.1 (00-03-26)	Date of last parameterisation	
!	End of log	

<sup>1)</sup> If the sequence is parameterised as month.

## Notes

By parameterisation, the energy supply company can select between a standard identification and its own identification. The standard identification has the following structure:

/LGZ...	Manufacturer	(Landis+Gyr)
/LGZ 4...	Transmission rate 4 = 4800 bps	
/LGZ4 \2...	Extended communication possibility 2 = DLMS-compatible meter	
/LGZ4\2 ZMD310...	Meter	Type of measuring unit
/LGZ4\2ZMD310 41...		Basic version tariff section
/LGZ4\2ZMD31041 00...		Additional functions (auxiliary power supply)
/LGZ4\2ZMD3104100 .B32		Firmware version

Stored values	The hyphen following the identification number and the rate (1.6.1) denotes the type of resetting:	
e.g. 1.6.1*04	*04	Resetting made internally or remote controlled
e.g. 1.6.1&04	&04	Resetting performed manually
The identification by the energy supply company itself uses an identification number. ID1.1 (designation of ownership by the energy supply company), ID1.2 (any desired number) or ID2.1 (serial number) are available. The identification is comprised as follows in this case:		
/LGZ...	Manufacturer	(Landis+Gyr)
/LGZ 4...	Transmission rate 4 =	4800 bps
/LGZ4 \2...	Extended communication possibility 2 =	DLMS-compatible meter
/LGZ4\2 \B32...	Meter	Firmware version
/LGZ4\2\B32 12345678	Identification number specified by parameterisation (maximum 8 characters)	

## 5.7.2 Readout to DLMS

While the readout according to IEC 62056-21 uses a predefined protocol, readout to DLMS enables the power supply company to read out values individually. The company therefore has systematic access to specific values without being influenced by other values that are not required.

### DLMS specification

Various meter manufacturers – including Landis+Gyr – together with related organisations, have compiled the language specification DLMS (Device Language Message Specification).

### Objective

The objective of DLMS is to use a common language for data exchange in energy measurement and other sectors. In addition to end units such as meters, tariff units, etc. DLMS also defines the interfaces, transmission channels and system software.

### Principle

DLMS delivery oriented protocol can be compared to sending a letter: the sender writes the address of the recipient on the letter and hands it to the post office for transport. The way in which the postal department transports the letter is of no consequence to the sender and receiver. The only important thing is that the address of the recipient is clearly shown and that the letter is received, read and it can be seen from whom the letter originates.

Units with DLMS operate in a similar way. They provide the values – termed objects – required by the receiver (e.g. control centre) and pass them via interface to the transport medium (channel). How the values reach the recipient is again immaterial for both parties.

### DLMS items

DLMS is an object-oriented language. The DLMS objects

- have an unique name in the form of the EDIS identification number
- contain the value in an exactly defined form and
- are configured in a similarly exactly defined format.

Examples are number of resets with date and time, cumulative maxima, rolling mean values, maxima, energy status, associated stored values, etc.

The sender feeds these objects to a transport medium, e.g. the telephone network. This transmits them to the receiver, so that the objects are received in the same form as supplied by the sender.

## 5.8 Input of formatted commands

The following operating data or meter characteristics can be modified by the input of formatted commands. The user of formatted commands, however, must have the necessary access authorisation according to the security system.

The following commands can be used both according to IEC 62056-21 and also with DLMS:

- Set time/date
- Set identification numbers for the energy supply company and for the manufacturer (by line).
- Reset
- Neutralise reset inputs KA/KB
- Set/reset reset counter
- Control tariff rates via interface
- Set/reset energy registers
- Set/reset total energy registers
- Set/reset demand maximum registers
- Set/reset power factor registers
- Reset stored values
- Reset battery hours counter
- Reset voltage failures registers
- Switch on/off increased resolution (test mode) of energy registers
- Define by additional parameters whether the optical test output for active energy in test mode supplies active or reactive energy pulses
- Delete error messages
- Change passwords P1,P2 and W5
- Reset load profile 1 / load profile 2
- Reset event log
- Reset dedicated event log groups

The following commands can only be executed with DLMS:

- Reset event register
  - Under- and over-voltages
  - Demand messages
  - Current messages
  - Power factor messages
- Set thresholds for messages

Formatted commands are transferred to the meter with a suitable device via the optical interface or via an interface circuit of the communication unit.

### 5.9 Set time and date, ID numbers, battery time

The following values can be changed at any time from the service menu (set mode):

- Date and time
- Identification numbers
- Operating time of battery

Below is an example on how to set the date and time.

			Operating display
1.		All segments of the display are lit 	Display check
2.		Enter service menu 	Set mode
3.		Enter set mode 	Identification number
4.		Select required setting 	Date, old value
5.		Select digit to be changed 	Digit flashes
6.		Change digit value 	Digit flashes
7.		Select digit to be changed 	Next digit flashes
8.		Repeat steps 5 – 7 for all digits to be changed.	All digits flash
9.		Confirm new setting 	Date, new value
10.		Repeat steps 4 – 9 for all settings to be changed.	
11.		Advance display until <b>End</b> 	End of set mode
12.		Back to service menu 	Service menu
13.		Advance display until <b>End</b> 	End of service menu
14.		Back to operating display 	Operating display
15.		Close and re-seal the front door.	



## 6 Service

This section describes the necessary servicing work after the appearance of operating faults or error messages.

### 6.1 Operating faults

If the liquid crystal display is illegible or the data readout does not function, the following points should first be checked:

1. Is the network voltage present (supply fuses intact and test terminals closed)?
2. Is the maximum permissible ambient temperature exceeded?
3. Is the plastic viewing window over the faceplate clean (not scratched, painted over, misted over or soiled in any way)?



#### Danger of short-circuits

Never clean soiled meters under running water or with high pressure devices. Water penetration can cause short-circuits. If the meter is heavily soiled, it should be uninstalled if necessary and sent to an authorised service and repair centre, so that a new plastic viewing window can be fitted.

---

If none of the points listed is the cause of the fault, the meter should be disconnected, removed and sent to the responsible service and repair centre (according to section 6.3 "Repairing meters").

### 6.2 Error messages

The meters regularly perform an internal self-test. This checks the correct function of all important parts.

In case of a serious error detected (fatal or critical error according to classification in the following degrees of severity), the meters displays an error code. This error code appears as an eight-digit number together with "F.F" or "FF" in the display (error code F.F 00000000 = no error).

#### Classification of degree of severity

The degree of severity of an error occurring is assessed as follows:

A **fatal error** indicates a severe problem, which prevents the meter maintaining measuring operation, e.g. a defective hardware component. The meter stops its operation and the error code is displayed permanently. The meter must be exchanged.

A **critical error** indicates a severe problem, but with which the meter continues to function and measurement is still possible. The data are stored in the memory and suitably marked in case of doubt. After a critical error, the error code is displayed until acknowledged with the display button or until the error register is reset, e.g. via the electrical interface. Depending on the type of the error this can cyclically occur again, since with the acknowledgement the error cause is usually not repaired. The meter must in this case be exchanged as soon as possible.

**Non-critical errors** can influence the meter functions (temporarily or permanently). These errors are recorded in the error register. The meter remains serviceable and normally needs not to be exchanged.

### Deleting error messages

If nothing else is specified in the following description of the error groups, the error messages can only be deleted with formatted commands (see section 5.8 "Input of formatted commands"). If the error occurs again, the meter should be removed and sent to the responsible service and repair centre (according to section 6.3 "Repairing meters").

### 6.2.1 Structure of an error message

An error message has the following form:



Figure 63. Error message on E650 meters

All E650 meters use the same format for error messages. It consists of four groups of 2 digits each, whereby the groups have the following significance:

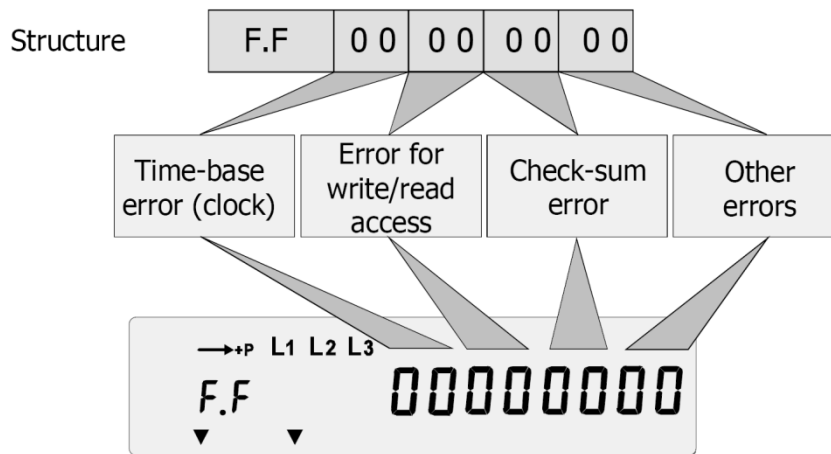

Figure 64. Significance of error message

Each group has two digits written in hexadecimal notation and can therefore have the values 0 to 9 and letters A to F. Both digits each form the sum of the individual values of 4 possible types of error as shown in the following diagrams.

### 6.2.2 Error groups

#### Time-base errors (clock)

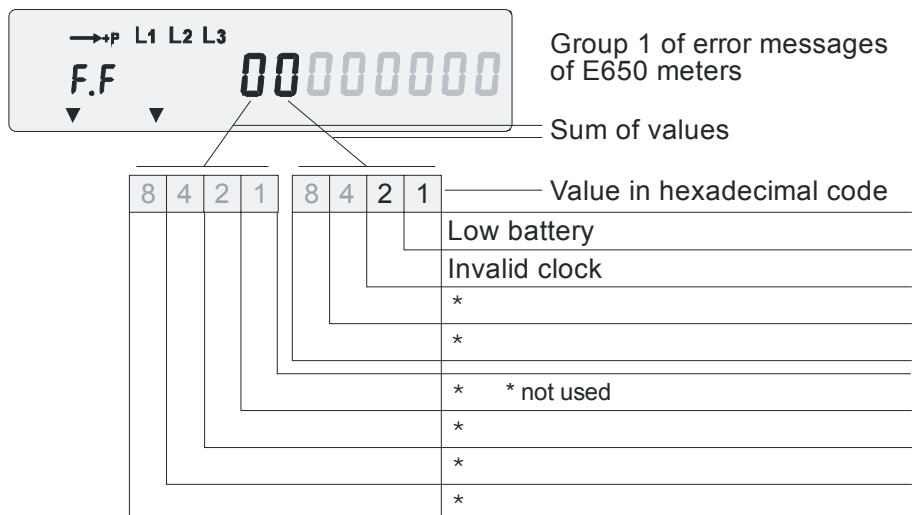

Figure 65. Group 1 of error messages

The first digit in the first group has no significance, since no error messages are assigned to it.

The second digit can have values between 0 (no error message) and 3 (both error messages set). Significance:

F.F 01 00 00 00

**Low battery** (non-critical error)

The battery is missing or discharged. If there is no mains voltage at the meter and the internal supercapacitor is discharged (after about 3 weeks) then the calendar clock will stop.

The error is deleted automatically when the battery voltage has again reached a sufficient value (e.g. after inserting a new battery as described in section 7.2 "Changing the battery").

This error message only appears if the meter is parameterised as "fitted with battery". Otherwise there is no check of the battery condition.

The same applies to messages where the bit is set:

F.F 03 ... ..

F.F 02 00 00 00

**Invalid clock** (non-critical error)

The meter has found that the calendar clock has stopped at some time, e.g. due to insufficient power reserve (battery low). The clock is running, but shows the wrong time and/or date.

The error is deleted automatically when the time and date have been set correctly by the relevant formatted command or manually in the set mode (see section 5.8 "Input of formatted commands". or section 5.9 "Set time and date, ID numbers, battery time"). If necessary, replace the battery.

The same applies to messages where the bit is set:

F.F 03 ... ..

**Errors for write/read access**

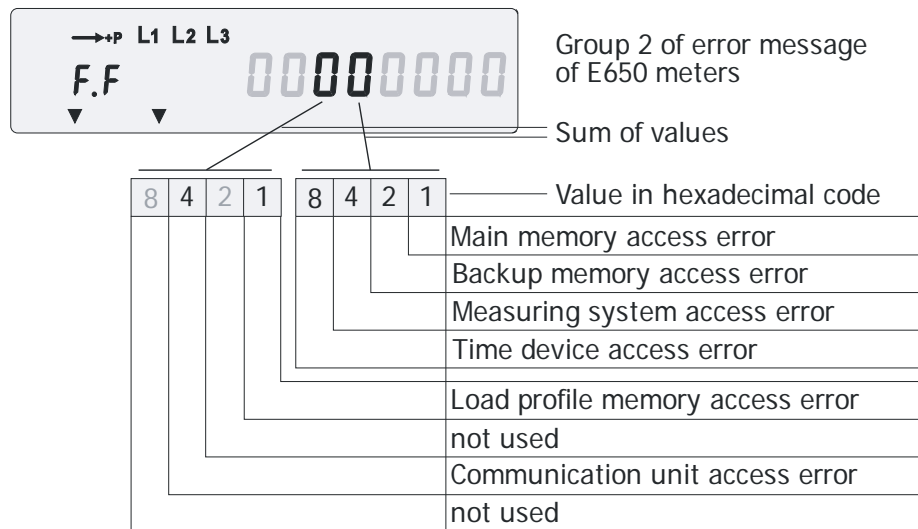

Figure 66. Group 2 of error messages

In the second group both digits can have values between 0 (no error message) and F (all four error messages set). Significance:

F.F 00 x1 00 00

**Main memory access error** (fatal error)

This error message appears if the main memory could not be accessed several times during the start-up of the meter.

**The meter may contain incorrect data and must be exchanged.**

The same applies to messages where the bit is set:

F.F .. x3/x5/x7/x9/xB/xD/xF .. ..

F.F 00 **x2** 00 00

**Backup memory access error** (non-critical error)

This error message appears if the backup memory could not be accessed several times.

**The meter may contain incorrect data and must be exchanged.**

The same applies to messages where the bit is set:

F.F .. x3/x6/x7/xA/xB/xE/xF .. ..

F.F 00 **x4** 00 00

**Measuring system access error** (non-critical error)

This error message appears in case of repeated failures when accessing the measuring system, possibly because of a completely discharged supercapacitor, which causes an incorrect start-up behaviour.

**Power-up meter and wait for a short time, then clear error via communication.** If the error does not reoccur, it is recommended to equip the meter with a battery. If the error reoccurs, replace the meter.

The same applies to messages where the bit is set:

F.F .. x5/x6/x7/xC/xD/xE/xF .. ..

F.F 00 **x8** 00 00

**Time device access error** (non-critical error)

The meter sets this message in the event of repeated failures when accessing the time device. The calendar clock may display an invalid time or date.

**The error can be reset via communication.** If it occurs repeatedly, the meter must be exchanged.

The same applies to messages where the bit is set:

F.F .. x9/xA/xB/xC/xD/xE/xF .. ..

F.F 00 **1x** 00 00

**Load profile memory access error** (critical error)

This error message appears in case of repeated failures when accessing the load profile memory.

Load profile data will be marked in the status code (bit 2 "corrupted measurement" and bit 0 "critical error" set).

It may not be possible to access the load profile memory. The memory may contain incorrect data. **The meter must be exchanged.**

The same applies to messages where the bit is set: F.F .. 5x .. ..

F.F 00 **4x** 00 00

**Communication unit access error** (non-critical error)

The meter sets this message in the event of repeated failures to access the communication unit. Communication fails or is slow.

**The error can be reset via communication.** If it reoccurs, replace first the communication unit, check the function again. If the error still occurs, the meter must be exchanged.

The same applies to messages where the bit is set: F.F .. 5x .. ..

**Checksum errors**

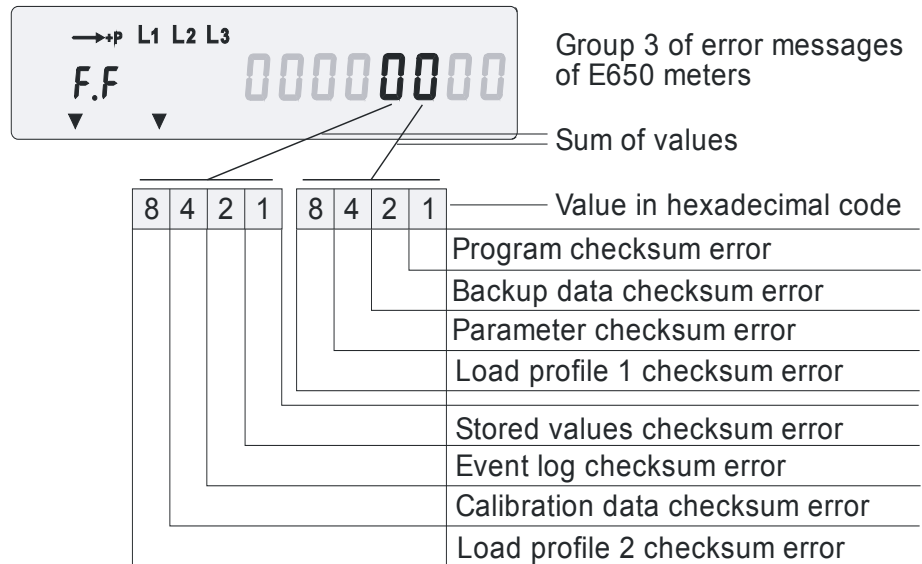

Figure 67. Group 3 of error messages

The first digit in the third group can have the value 0 (no error message) or 1 (error message set).

The second digit can have values between 0 (no error message) and F (all four error messages set). Significance:

F.F 00 00 **x1** 00

**Program checksum error** (fatal error)

**The meter does not operate and must be exchanged.**

The same applies to messages where the bit is set:

F.F .. .. x3/x5/x7/x9/xB/xD/xF ..

F.F 00 00 **x2** 00

**Backup data checksum error** (critical error)

This error message appears when the backup data checksum test fails.

Load profile data will be marked in the status code (bit 2 "corrupted measurement" and bit 0 "critical error" set). **The meter may contain incorrect data and must be exchanged.**

The same applies to messages where the bit is set:

F.F .. .. x3/x6/x7/xA/xB/xE/xF ..

F.F 00 00 **x4** 00

**Parameter checksum error** (critical error)

This error message appears when the parameter checksum test fails.

Load profile data will be marked in the status code ("bit 0 "critical error" set). **The meter may contain incorrect data and must be exchanged.**

The same applies to messages where the bit is set:

F.F .. .. x5/x6/x7/xC/xD/xE/xF ..

F.F 00 00 **x8** 00

**Load profile 1 checksum error** (non-critical error)

Load profile 1 data of the defective memory area will be marked in the status code (bit 2 "corrupted measurement" set).

**The error can be reset via communication.** Reset the load profile first and then the error. If it occurs repeatedly, the meter must be replaced as soon as possible.

The same applies to messages where the bit is set:

F.F .. .. x9/xA/xB/xC/xD/xE/xF ..

F.F 00 00 1x 00

**Stored values checksum error** (critical error)

Data in the defective memory area will be marked in the status code (bit 0 "critical error" set).

**The error can be reset via communication.** If it occurs repeatedly, the meter must be replaced as soon as possible.

The same applies to messages where the bit is set:  
F.F .. .. 3x/5x/7x/9x/Bx/Dx/Fx ..

F.F 00 00 2x 00

**Event log checksum error** (non-critical error)

Data in the defective memory area will be marked in the status code (bit 0 set).

**The error can be reset via communication.** If it occurs repeatedly, the meter must be replaced as soon as possible.

The same applies to messages where the bit is set:  
F.F .. .. 3x/6x/7x/Ax/Bx/Ex/Fx ..

F.F 00 00 4x 00

**Calibration data checksum error** (critical error)

Data in the defective memory area will be marked in the status code (bit 0 "critical error" set).

**The meter must be replaced as soon as possible.**

The same applies to messages where the bit is set:  
F.F .. .. 5x/6x/7x/Cx/Dx/Ex/Fx ..

F.F 00 00 8x 00

**Load profile 2 checksum error** (non-critical error)

Load profile 2 data of the defective memory area will be marked in the status code.

**The error can be reset via communication.** Reset the load profile first and then the error. If it occurs repeatedly, the meter must be replaced as soon as possible.

The same applies to messages where the bit is set:  
F.F .. .. 9x/Ax/Bx/Cx/Dx/Ex/Fx ..

**Other errors**

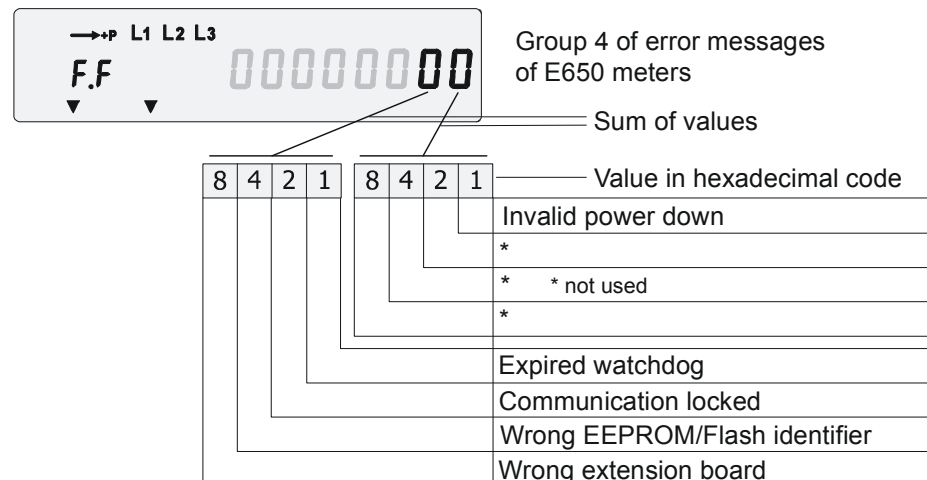

Figure 68. Group 4 of error messages

The first digit in the fourth group can have the values 0 to F.

The second digit can have values between 0 (no error message) and 1 (Invalid power down). Significance:

F.F 00 00 00 <b>x1</b>	<p><b>Invalid power down</b> (non-critical error)</p> <p>The meter has detected that the last data storage was not performed correctly. The meter may contain incorrect data or may have lost data since the last storage, i.e. for 24 hours maximum.</p> <p><b>The error can be reset via communication.</b> If it occurs repeatedly, contact Landis+Gyr Customer Services.</p>
F.F 00 00 00 <b>1x</b>	<p><b>Expired watchdog</b> (non-critical error)</p> <p>The microprocessor was restarted due to a disturbance (e.g. lightning). The meter may lose all data recorded since the last storage, i.e. for 24 hours maximum.</p> <p><b>The error can be reset via communication.</b> If it occurs repeatedly, contact Landis+Gyr Customer Services.</p> <p>The same applies to messages where the bit is set: F.F .. .. 3x/5x/7x/9x/Bx/Dx/Fx</p>
F.F 00 00 00 <b>2x</b>	<p><b>Communication locked</b> (non-critical error)</p> <p>This error indicates access attempts via the communication interface with wrong passwords.</p> <p><b>The error is automatically deleted</b> after the inhibition time or at midnight.</p> <p>The same applies to messages where the bit is set: F.F .. .. 3x/6x/7x/Ax/Bx/Ex/Fx</p>
F.F 00 00 00 <b>4x</b>	<p><b>Wrong EEPROM/Flash</b> (fatal error)</p> <p>Incorrect EEPROM/ Flash memory is installed in meter.</p> <p><b>The meter does not operate and must be exchanged.</b></p> <p>The same applies to messages where the bit is set: F.F .. .. 5x/6x/7x/Cx/Dx/Ex/Fx</p>
F.F 00 00 00 <b>8x</b>	<p><b>Wrong extension board</b> (non-critical error)</p> <p>Identification of extension board differs from that parameterised in the meter.</p> <p>The meter might not have the required functions such as data profile, control inputs or output signals. <b>The meter has to be exchanged.</b></p> <p>The same applies to messages where the bit is set: F.F .. .. 9x/Ax/Bx/Cx/Dx/Ex/Fx</p>

## 6.3 Repairing meters

Meters must only be repaired by the responsible service and repair centre (or manufacturer).

The following procedure should be adopted if a meter repair is necessary:

1. If the meter is installed, remove the meter as described in section 4.7 "Uninstallation" and fit a substitute meter.
2. Describe the error found as exactly as possible and state the name and telephone number of the person responsible in case of inquiries.
3. Pack the meter to ensure it can suffer no further damage during transport. Preferably use the original packing if available. Do not enclose any loose components.
4. Send the meter to the responsible service and repair centre.

## 7 Maintenance

This section describes the necessary maintenance work.

### 7.1 Meter testing

Meter tests should be performed at periodic intervals according to the valid national regulations (either on all meters or on specific random samples). In principle, the meters should be uninstalled for this purpose according to the instructions in section 4.7 "Uninstallation" and replaced by a substitute meter. The meter test can also be performed on the spot in certain circumstances.

#### 7.1.1 Test mode

The test mode permits increasing the resolution of the energy registers by 1 to 5 digits. This allows the energy supply company to carry out the so called measuring unit test in a reasonably short time.

In test mode, the same registers shown as a rolling list in the operating display are always displayed, but with high resolution and not rolling.

The energy registers comprise a total of 12 digits. A maximum of 8 digits, however, is shown on the display. The effective number of digits shown and the number of decimal places are determined by the parameterisation. For the test mode, more decimal places are normally parameterised (maximum 5) to permit a quicker test of the transmission to the energy registers.

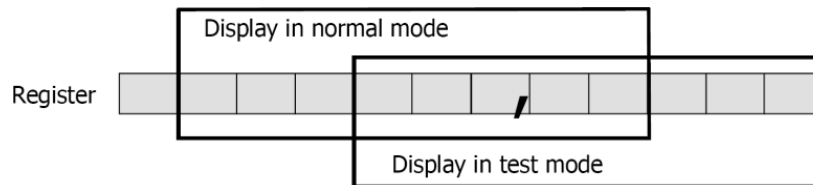

Figure 69. Display changeover normal mode – test mode

Changeover from normal to test mode and back is made by formatted commands (see section 5.8 "Input of formatted commands") or manually in the service menu.

In test mode, the optical test output for active energy can also provide reactive energy pulses depending on the parameterisation. Reactive energy pulses are supplied to this test output if the register shown on the display represents a reactive energy register. Active energy pulses are supplied for all other measured values shown as in normal operating mode. Formatted commands can also be used to define whether the optical test output for active energy in test mode should supply active or reactive energy pulses, independent of the type of register shown on the display. This permits changeover without manual intervention.

#### 7.1.2 Measuring times

For technical reasons, greater measuring deviations can occur during short-term measurements. It is therefore recommended to use sufficiently long measuring times in order to achieve the required accuracy.



Table of measuring times required at the optical test output:

**ZMD300xT**

$U_n = 230\text{ V}$   
 $I_b = 5\text{ A}$

Current [% $I_b$ ]	Measuring uncertainty 0.1 %		
	3 P $\cos\varphi=1$	1 P 1	3 P 0,5
5	40 s	40 s	90 s
10	20 s	20 s	40 s
20	10 s	10 s	20 s
50	8 s	8 s	10 s
100	6 s	6 s	8 s
1000	6 s	6 s	6 s
2000	6 s	6 s	6 s
2400	6 s	6 s	6 s

3 P = universal  
1 P = single-phase

**7.1.3 Optical test output**

The red optical test outputs on the meter above the LCD should be used for meter testing. These supply pulses at a frequency dependent on the meter constant R, whereby the rising edge is always decisive for the test.

Note that the digital signal processing provides a delay of 2 seconds between the instantaneous power at the meter and the appearance of the pulses at the optical test outputs. No pulses are lost.

The number of pulses per second for the desired power is obtained by multiplying the meter constant R by the power in kW divided by 3600.

Example: Meter constant R = 1000

Power P = 35 kW

$$f\text{-test output} = R \times P / 3600 = 1000 \times 35 / 3600 = 10\text{ imp/s}$$





The optical test outputs are continuously lit at no-load.

**Test mode**

The test mode enables you to select which measuring value (active, reactive) is shown on the optical test output.

In the display, values for active, reactive and apparent energy are available. Depending on parameter setting, the resolution of the display register can be increased for faster testing. In the test mode, the resolution is increased by one decimal point compared with the normal mode. A maximum of 5 decimal points is possible.

			Operating display	
1.		All segments of the display are lit		Display check
2.		Enter service menu		Set mode
3.		Select test mode		Test mode

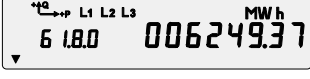
4.		Enter test mode		First value
5.		Select required value		Value x
6.		Repeat step 3 for all values to be tested		
7.		Exit test mode		Operating display



**Examples**

First value and value x are examples. The real values are defined in the parameter settings and are the same as the operating display.

The measured values are displayed at the optical test outputs as shown in the following table:

Mode	Register on Display	Test output reactive	Test output active
Normal mode	Some sort of register	R	A
Test mode	Reactive energy register	A	R
	Active energy register or one of not mentioned registers in this table.	R	A

**7.1.4 No-load test**

A test voltage  $U_p$  of  $1.15 U_n$  is used for the no-load test (creep test) to IEC 62053-21 (e.g.  $U_p = 265 V$  with  $U_n = 230 V$ ).

**Procedure:**

1. Disconnect the meter from the network for at least 10 seconds.
2. Then switch on the test voltage  $U_p$  and wait approx. 10 seconds. After this time the energy direction arrows must disappear. The red optical test outputs are permanently "lit".
3. Switch on test mode (high resolution).
4. The meter must not deliver more than one pulse during the no-load test. Check the energy levels for changes in test mode. They must not increase by more than the value of one pulse (see faceplate).

**7.1.5 Starting test active part**

**Procedure:**

1. Apply a load current of 0.1% of the base current  $I_b$  (IEC-meters) or 0.1% of the reference current  $I_{ref}$  (MID-meters) – e.g. 5 mA with  $I_b = I_{ref} = 5 A$  – and the voltage  $U_n$  (three-phase in each case) and  $\cos\phi = 1$ . The meter must remain in no-load.

- Increase the load current to 0.4%  $I_b$  (IEC-meters) or 0.4%  $I_{ref}$  (MID-meters) – e.g. 20 mA with  $I_b = I_{ref} = 5$  A. The energy direction arrow "P" must appear within 10 seconds. The optical test output for active energy consumption is no longer permanently "lit".

### 7.1.6 Starting test reactive part

#### Procedure:

- Apply a load current of 0.1% of the basic current  $I_b$  (e.g. 5 mA with  $I_b = 5$  A) and the voltage  $U_n$  (three-phase in each case) and  $\sin\phi = 1$ . The meter must remain in no-load.
- Increase the load current to 0.4%  $I_b$  (i.e. 20 mA with  $I_b = 5$  A). The energy direction arrow "Q" must appear within 10 seconds. The optical test output for active energy consumption is no longer permanently "lit".

## 7.2 Changing the battery

If the meter is provided with a battery, this must be changed if one of the following events occurs:

- The  symbol appears on the display.
- The battery has been in the meter for more than 10 years (preventive servicing). It is recommended to note the date of insertion on the battery. The 10 years depend on the product and on the age of the battery when inserting it into the meter.
- The battery operating hours counter indicates over 80,000 hours (can be read under code C.6.0 in service mode).
- The battery charge indicates less than 4.8 V (can be read under code C.6.1 in service mode).



#### Meters with or without battery

Only meters parameterised as "fitted with battery" have the  symbol and the battery operating hours counter.

---



#### Dangerous voltage on contacts in the battery compartment

The contacts in the battery compartment may have mains voltage applied. Therefore only remove the battery with the existing battery holder and insert the new battery only with the battery holder. Ensure that the contacts are never touched.

---



#### Replacement battery

As a replacement, use only a lithium battery with a rated voltage of 6 V and the same construction as the original battery.

---

#### Procedure:

- Remove the front door seal.
- Open the front door.  
The battery compartment is on the left below the liquid crystal display.

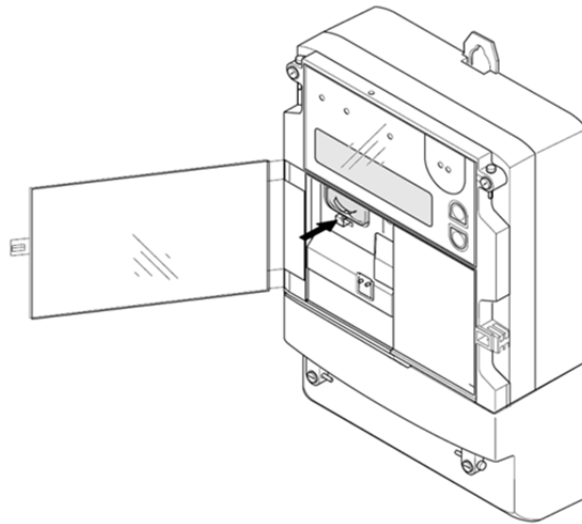

Figure 70. Battery compartment

3. Press on the latch of the plastic battery holder until it releases and then withdraw the battery holder with the old battery.

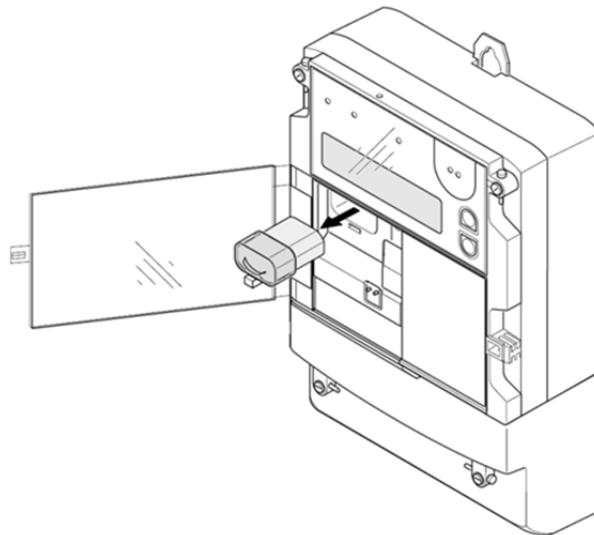

Figure 71. Removing the battery

4. Mark the current date on the new battery.
5. Withdraw the old battery from the holder and insert the new battery.
6. Push the battery holder with battery into the battery compartment until the latch engages.
7. Reset the battery hours counter to zero with the relevant formatted command (see section 5.8 "Input of formatted commands") or in the set mode (see section 5.9 "Set time and date, ID numbers, battery time").
8. Close the front door.
9. Re-seal the front door.
10. Dispose of old batteries as hazardous waste in accordance with local regulations.



#### Checking time-of-day and date

After inserting the battery, check the time-of-day and date without power applied and set these values again if necessary.

## 8 Disposal



### Electronic waste treatment

This product must not be disposed of in regular waste. Use a professional electronic waste treatment process.

The components used to manufacture the device can, in the main, be broken down into constituent parts and sent to an appropriate recycling or disposal facility. When the product is removed from use, the whole product must be sent to a professional electronic waste treatment process. The waste treatment and disposal plants must be approved by local regulatory authorities.

The end processing of the product and recycling of its components must always be carried out in accordance with the rules and regulations of the country where the end processing and recycling are done.

On request, Landis+Gyr will provide more information about the environmental impact of the product.



### Disposal and environmental protection regulations

The following are general guidelines and should NOT take priority over local disposal and environmental policies which should be adhered to without compromise.

Components	Disposal
Printed circuit boards, LEDs, LCD display	Delivered to recycling plants
Metal components	Sorted and delivered to metal recycling plants
Plastic components	Sorted and delivered to re-granulation if at all possible
Batteries	Removed from meter and delivered to specialised recycling plants

## 9 Index

.MAP110 .....	28	Control of display via optical interface .....	51
Active component .....	15	Cover detection unit .....	48
Active energy .....	18	Creep test .....	74
Active power .....	15	Critical error .....	65
Active power calculation .....	15	CS interface .....	14
Active power direction .....	52	Data preparation for billing .....	13
Additional control inputs .....	13	Data readout .....	60
Additional output contacts .....	13	Data readout via optical interface .....	60
Alert LED .....	59	Date and time	
Anti-tampering features .....	28	Set .....	64, 73
Apparent energy .....	19	DC magnet detection .....	29
Apparent energy calculation .....	19	Decommissioning .....	77
Aron circuit .....	40	Dedicated event log .....	23
Arrow symbols .....	53	Deleting error messages .....	66
Arrows for status indication .....	33	Device description .....	8
Automatic data readout .....	60	Digital intermediate values .....	15
Auxiliary power supply .....	13	Dimensions .....	39
Background lighting for LCD .....	52	Direct connection .....	8
Backup data checksum error .....	69	Direction of rotating field .....	21
Backup memory access error .....	68	Display .....	33, 52
Basic information for meter connection .....	40	Display buttons .....	30, 50
Basic layout of LCD .....	52	Display check .....	55
Battery charge status .....	75	Display examples .....	56
Battery compartment .....	31, 76	Display menu .....	55
Battery condition .....	53	Display range changeover .....	72
Battery exchange .....	75	Disposal .....	77
Battery operating hours counter .....	75	Disposal regulations .....	77
Billing data .....	13	DLMS items .....	62
Block schematic diagram .....	11	DLMS specification .....	62
Block schematic diagram of measuring unit .....	14	Dummy communication unit .....	31
Buttons .....	11	Electronic waste treatment .....	77
Calculation of apparent energy .....	19	Energy components .....	18
Calibration data checksum error .....	70	Energy consumption recording .....	60
Calibration stage .....	15	Energy magnitude .....	18
Case of meter .....	31	Environmental protection regulations .....	77
Changing the battery .....	75	Error code .....	65
Changing values in set mode .....	64	Error message .....	54, 65
Characteristics of meters .....	8	Error severity .....	65
Check of connections .....	46	Errors for write/read access .....	67
Checksum errors .....	69	Event log .....	23, 57
Combi-meter .....	8	Expired watchdog .....	71
Commissioning .....	46	Extended suspension hook .....	41
Communication .....	26	Extension board .....	13
Communication interface .....	14	Extension boards .....	36, 37, 38
Communication locked .....	71	External pulse transmitter .....	14
Communication unit .....	14, 64	Faceplate .....	33
Communication unit access error .....	68	Fatal error .....	65
Connecting conductor .....	40, 42	Field of application of meters .....	8
Connecting meter .....	42	Fixing of cover detection unit .....	48
Connecting phase connection lines .....	42	Form of fixing .....	41
Connecting signal inputs and outputs .....	44	Formation of mean values .....	16
Connection diagrams .....	2, 35, 50	Formation of measured quantities .....	18
Connection diagrams extension board .....	36	Four-quadrant measurement .....	19
Connections .....	34	Front door .....	31
Control elements .....	50	Functional check .....	46
Control inputs .....	11	Harmonics .....	15

Identification numbers .....	64	OBIS.....	81
IEC 62056-21 .....	60, 63	Objectivefor DLMS .....	62
Impulse inputs .....	14	Operating display .....	54
Index field.....	53	Operating faults.....	65
Index system.....	53, 81	Optical button .....	51
Input of formatted commands .....	63	Optical interface .....	30, 33, 64
Input signals.....	14	Optical test output .....	30, 59, 73
Inputs .....	11	Output contacts .....	34
Installation.....	40	Outputs.....	12
Interfaces .....	14	Ownership designation.....	34
Intermediate values.....	15	Parameter checksum error.....	69
Internal current transformers.....	14	Phase angles .....	21
Invalid clock .....	67	Phase connections.....	11
Invalid power down .....	71	Phase current.....	20
Laptop .....	60	Phase voltage .....	20
LCD.....	33, 52	Phase voltages.....	53
Liquid crystal display.....	33	Power factor .....	20
Lithium battery .....	75	Power supply.....	13
Load profile 1 .....	23	Profile 2.....	23
Load profile 2 (option) .....	23	Program checksum error.....	69
Load profile 2 checksum error .....	70	Pulse inputs.....	12, 14, 34
Load profile checksum error .....	69	Purpose of this manual .....	5
Load profile memory access error .....	68	Push buttons .....	11
Log example .....	60	Quadrant display .....	52
Low battery .....	67	Quadrants .....	19
Main characteristics of meters .....	8	Rapid run.....	56, 59
Main faceplate.....	33	Reactive component .....	16
Main memory access error .....	67	Reactive energy .....	18
Mains frequency.....	16, 21	Reactive power .....	15
Maintenance .....	72	Reactive power calculation .....	15
Manufacturer seal .....	30, 31	Reactive power direction.....	52
MAP120 .....	28	Reading head.....	60
Mean value formation .....	16	Readout device .....	60
Measured quantities.....	12, 17	Readout log.....	60
Measured quantity indication .....	34	Readout to DLMS.....	62
Measuring deviations .....	72	Readout to IEC 62056-21 .....	60
Measuring system.....	12	Recording counting pulses for other physical media.....	8
Measuring system access error .....	68	Reference documents .....	5
Measuring times.....	72	Releasing connection from spring-loaded terminal.....	45
Measuring uncertainty.....	73	Removing connections in spring-loaded terminals.....	48
Measuring unit .....	14	Removing meter.....	48
Memory .....	13	Repairing meters.....	71
Meter board.....	40	Replacement battery .....	75
Meter case .....	31	Reset button.....	31
Meter connection .....	42	Reset button R .....	51
Meter connections.....	34	Rolling display .....	54
Meter constant .....	73	Rotating field .....	16
Meter tests .....	72	RS232 interface .....	14
Modem .....	14	RS485 interface .....	14
Modifying operating data or meter characteristics .....	63	S0 interface .....	14
Natural error compensation .....	15	Safety	
Neutral .....	40	Information.....	6
Neutral current.....	20	Regulations.....	7
No-load test.....	74	Responsibilities.....	6
Non-critical errors.....	65	Seal component .....	32, 33
Normal mode .....	72		
Numbering of quadrants .....	19		

Sealing.....	30, 46	Tariff faceplate .....	34
Sealing with padlock.....	32	Telemetry.....	8
Seals.....	30	Terminal cover .....	30, 31
Self-tests.....	54, 65	Terminal cover detection .....	29
Series designation .....	10	Test mode.....	72, 73, 74
Service.....	65	Test voltage .....	74
Service and repair centre .....	71	Testing meter.....	72
Service menu.....	58	Time device access error.....	68
Set date and time .....	64	Time-base errors .....	66
Set identification numbers .....	64	Total active energy .....	18
Set mode .....	59, 64	Total apparent energy.....	19
Set operating time of battery .....	64	Total harmonic distortions.....	21
Severity of errors .....	65	Total reactive energy .....	18
Signal processing .....	12	Transmission contact.....	8
Signal processor.....	15, 16	Type designation .....	10
Signal utilisation.....	12	Type of measurement ZMD400xT .....	14
Software tools.....	27	Types of display .....	54
Software version.....	11	Types of error .....	66
Spring-loaded terminals.....	35	Uninstallation .....	48
Standard data .....	55	Units field.....	53
Starting test .....	74	Utility seal .....	30, 31
Status indication arrows .....	33	Value display .....	56, 58
Stored value profile.....	23	Value field.....	53
Stored values checksum error.....	70	Verification seal .....	30, 31
Structure of error messages .....	66	Viewing window .....	31
Substitute meter .....	49, 71, 72	Voltage divider.....	14
Summation channels .....	22	Wrong EEPROM/Flash.....	71
Suspension eyelet .....	41	Wrong extension board.....	71
Suspension triangle .....	41	Zero passage.....	16, 21
Target group of this manual.....	5	ZMD300AT/CT.....	8
Tariff control.....	13		



# Appendix 1 OBIS code

## Object Identification System

The OBIS code (Object Identification System) is structured as follows:

<b>A</b>	<b>B</b>	<b>C</b>	<b>D</b>	<b>E</b>	<b>F</b>	Value group
<b>M-</b>	<b>KK:</b>	<b>GG.</b>	<b>AA.</b>	<b>T</b>	<b>W</b>	According to VDEW

### A: Medium [1 ... 9]

Defines the medium used. If only one medium is used it does not have to be specified. The Values represent the following objects:

- 1 Electricity
- 2, 3 Not used
- 4 Heating costs
- 5 Cooling system
- 6 Heating system
- 7 Gas
- 8 Cold water
- 9 Hot water

### B: Channel [1 ... 64]

Defines the channel number, i.e. the number of the input of a metering equipment with several inputs for the measurement of energy of the same or different types (e.g. in data concentrators, registration units). This enables data from different sources to be identified. If only one channel (only one meter) is used, it does not have to be specified.

### C: Measured quantity [1 ... 99]

Defines the abstract or physical data items related to the information source concerned, e.g. active power, reactive power, apparent power,  $\cos\varphi$ , current or voltage.

<b>General data</b>		0			
<b>Active energy</b>	<b>+ (import)</b>	$\sum Li$ 1	L1 21	L2 41	L3 61
	<b>- (export)</b>	2	22	42	62
<b>Reactive energy</b>	<b>+</b>	3	23	43	63
	<b>-</b>	4	24	44	64
	<b>QI (quadrant I)</b>	5	25	45	65
	<b>QII</b>	6	26	46	66
	<b>QIII</b>	7	27	47	67
	<b>QIV</b>	8	28	48	68
<b>Apparent energy</b>	<b>+ (import)</b>	9	29	49	69
	<b>- (export)</b>	10	30	50	70
<b>Current</b>		11	31	51	71
<b>Voltage</b>		12	32	52	72
<b>Power factor</b>		13	33	53	73
<b>Frequency</b>		14			
<b>Service data</b>		C			
<b>Error message</b>		F			
<b>Profile data</b>		P			

**D: Measuring type**  
[1 ... 73, F, P]

Defines types, or the result of the processing of physical quantities according to various specific algorithms. The algorithms can deliver energy and demand quantities as well as other physical quantities.

The following list is an excerpt.

<b>Capture period</b>	1	2	3
<b>Cumulated minimum</b>	1	11	21
<b>Cumulated maximum</b>	2	12	22
<b>Minimum</b>	3	13	23
<b>Running average</b>	4	14	24
<b>Last average</b>	5	15	25
<b>Maximum</b>	6	16	26
<b>Instantaneous value</b>	7		
<b>Time integral 1 (energy status)</b>	8		
<b>Time integral 2 (energy consumption)</b>	9		
<b>Time integral 3 (excess consumption)</b>	10		
...			
<b>Test average</b>	55		
<b>Test time integral 4</b>	58		
...			
<b>Error message</b>	F		
<b>Load profile</b>	01		

**E: Tariff**  
[1 ... 9]

Defines the further processing of measurement results to tariff registers, according to the tariffs in use. Total values are marked with '0'. For abstract data or for measurement results for which tariffs are not relevant, this value group can be used for further classification.

**F: Stored value**  
[01 ... 99]

Defines the storage of data according to different billing periods. Where this is not relevant, this value group can be used for further classification.

**Display code**

To simplify the reading of the display code, individual parts of the OBIS code can be omitted. The abstract or physical data C and type of data D must be shown.

**Examples**

- 1.8.0**      1 = all-phase active power in positive direction  
                  8 = cumulative value (meter reading)  
                  0 = total energy (no tariffs)
- 0.9.1**      Local time



**Contact:**

Landis+Gyr AG  
Theilerstrasse 1  
CH-6301 Zug  
Switzerland  
Phone: +41 41 935 6000  
[www.landisgyr.com](http://www.landisgyr.com)

Landis  
| Gyr+  
manage energy better